

ILLINOISTM

COUNTRY LIVING

June 1998

River to River Run

Popular event
spreads economic
benefits from the
Mississippi to the Ohio

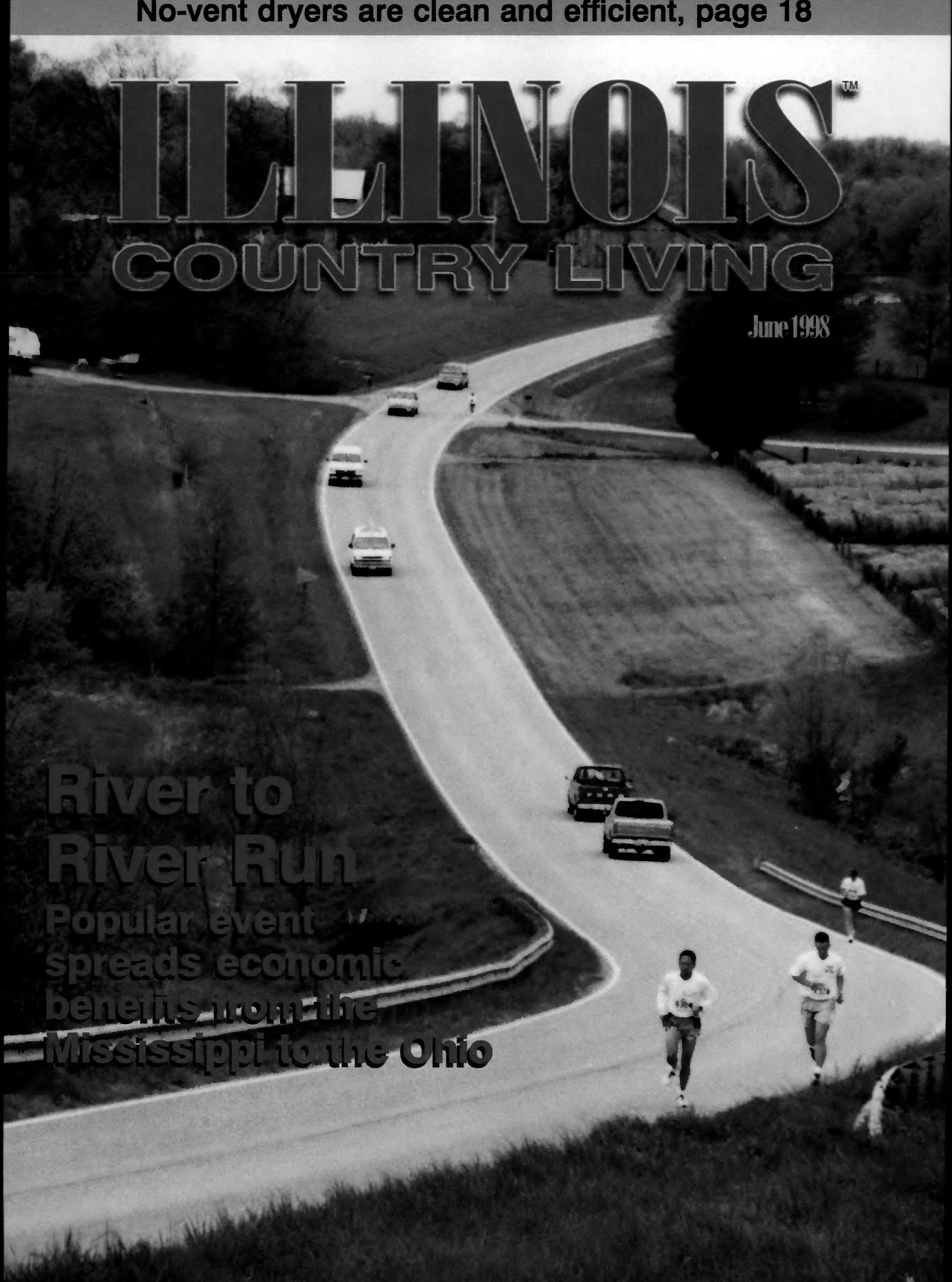

Join the Club.



Cut up to 60% off your heating and cooling bills. Receive heating, air conditioning and hot water from a single, compact unit — and slow the depletion of the Earth's resources. All with a WaterFurnace geothermal comfort system.

A WaterFurnace taps the geothermal energy stored in your own backyard to heat and cool your home. Saving you money and the environment for generations to come. Call 1-800-Geo-Save or your trained and authorized WaterFurnace dealer today to learn more. Or visit our web site at <http://www.waterfurnace.com>.



WaterFurnace®

#1 Residential Geothermal System installed in Illinois over the past ten years.

Arnold Brothers Heating & Cooling
Macomb, IL, 309-833-2852

Boyce Electric
Cissna Park, IL, 815-457-2700

Burgess & Son, Inc.
Girard, IL, 217-627-2665

Charlie's Air Conditioning
Cartersville, IL, 618-985-2502

Collins Plumbing & Heating
Springfield, IL, 217-793-8031
Petersburg, IL, 217-632-3670

Comfort Mechanical
Gibson City, IL, 217-784-4422

Den-Son Inc. Cooling & Heating
Brighton, IL, 618-372-3875

DeRousse Heating & Air Conditioning
Red Bud, IL, 618-282-2224
Chester, IL, 618-826-4359

Design Air Heating & Air Conditioning
Decatur, IL, 217-429-1105, 800-452-7845

Electro Electric
Flora, IL, 618-662-4520

Energy Specialists
Toluca, IL, 800-782-7491

Holloway Heating & Air Conditioning
Mt. Vernon, IL, 618-242-5481

HovelN Heating & Cooling
Thomasboro, IL, 217-643-2125

Jeckel Plumbing & Heating
Delavan, IL, 309-244-8265

Jansen's Heating & Air Conditioning
Effingham, IL, 217-347-5223

Kupferschmid, Inc.
Pontiac, IL, 815-842-3812
Forrest, IL, 815-657-8147

LD Mechanical Contractors, Inc.
Charleston, IL, 217-345-9633

Macari Service Center
Shelbyville, IL, 217-744-4214

Middleton Heating & Cooling Inc.
Cobden, IL, 618-893-2821

Mike's Heating & Air
Simpson, IL, 618-695-2756

Peters Heating & Air Conditioning, Inc.
Quincy, IL, 217-222-1368
Pittfield, IL, 217-285-1600

R & M Electric
Watseka, IL, 815-432-4062

Stein Heating & Cooling
Hardin, IL, 618-576-2313

Toennies Service Co.
Alber/Damiansville, IL, 618-248-5130

Triangle Heating & Cooling
Tuscola, IL, 217-253-5400

Williams Air Conditioning & Heating, Inc.
Murphysboro, IL, 618-684-3606
Steelville, IL, 618-965-2040

Yard Heating & Cooling
Taylorville, IL, 217-824-4737

Published by
Association of Illinois
Electric Cooperatives

John Lowrey
Editor
Jack D. Halstead
Senior Editor
Janeen Keener,
Joseph W. Richardson
Associate Editors
Sandy Wolske
Advertising Coordinator
Elayne Rhodes
Administrative Assistant
Cheryl Howard, Lisa Riddle
& Erin Weller
Graphic Designers
Derek Squires
Graphic Technician
Angie Bingenheimer
Circulation Coordinator

Illinois Country Living is a monthly publication serving the communications needs of 21 locally owned, not-for-profit Illinois electric cooperatives. Over 148,000 families receive the magazine as part of their electric cooperative membership. Monthly columns and stories provide information about topics and issues that affect the quality of their lives.

Illinois Country Living (USPS number 258-420) is published monthly and is the official publication of the Association of Illinois Electric Cooperatives, 6460 South Sixth Frontage Road, Springfield, IL 62707. The cost is \$2.40 plus postage per year for members of subscribing cooperatives and \$5 per year for all others. Periodical postage paid at Springfield, Illinois, and additional mailing offices.

POSTMASTER: Send address changes to: Illinois Country Living, P.O. Box 3787, Springfield, Illinois 62708.

CO-OP MEMBERS: When requesting an address change, please include the name of your cooperative. Telephone: (217) 529-5561

Advertising and editorial inquiries should be directed to Illinois Country Living, P.O. Box 3787, Springfield, Illinois 62708. National advertising representative: The Weiss Group, 13751 Lake City Way NE, Suite 102, Seattle, WA 98125. Acceptance of advertising by ICL does not imply endorsement by the publisher or the electric cooperatives of Illinois of the product or service advertised. Advertisers are screened by the publisher and every effort is made to protect the subscriber, but ICL is not responsible for the performance of the product or service advertised.

EDITORS: Articles appearing in Illinois Country Living may be reprinted upon consent of the editor. For permission phone (217) 529-5561 or write to John Lowrey, editor, Illinois Country Living, P.O. Box 3787, Springfield, IL 62807.

COVER STORY

10 River to River Run

A Southern Illinois run has become so popular that many runners now are turned away. But area merchants are embracing the race as an important part of the region's emerging tourism economy.



DEPARTMENTS

4 ILLINOIS COMMENTARY

When agricultural interests unite, good things happen. Illinois Farm Bureau President Ron Warfield notes some success stories.

8 ILLINOIS CURRENTS

Touchstone Energy, how to thwart nibbling deer, new safety program, and more on Illinois wine.

14 SAFETY AROUND YOUR HOME

Protect yourself and your family – especially elders – from consumer fraud.

16 YOUR YARD AND GARDEN

Mosquito problems in your yard can be reduced. Here are some abatement tips for your yard or pond.

18 TODAY'S TECHNOLOGY AND YOU

No-vent dryers last a lifetime, may be located anywhere in your home, and are energy efficient.

22 ILLINOIS' FINEST COOKING

Our recipes come this month from the Every-Other-Friday-Night Happy Hour Group of Bloomington and the LaSalle County Homemaker's Extension Association.



26 ILLINOIS MARKETPLACE

29 ILLINOIS DATEBOOK

Bloomington Gold returns to Bloomington and Metropolis honors Superman. Celebrate National Trails Day, or take in a river festival. It's summer time!

Illinois COMMENTARY

Disparate voices find unity

Teamwork doesn't come easily. Electric co-op leaders know that. It took a lot of work to transform the dreams of early co-op leaders into the sound system which serves today. Yet, it was worth the effort.

The same commitment to joint effort is required for the challenges facing Illinois agriculture.

Decades ago, when farm interests dominated, agriculture could afford the luxury of competing viewpoints. Years later, when demographics made us a minority, shrewd politicians took the upper hand with the charge: "When you can all get together on a position, come back — and then we will see what we can do for agriculture!"



Ronald R. Warfield

Illinois agriculture has seen the light. Our once divided energies are teamed. The Illinois Agricultural Legislative Roundtable brings nearly all segments

of Illinois' vast agriculture together to partner for action.

Encompassing more than 50 groups, the Roundtable meets formally twice each year. All proposals are discussed. Issues where obvious disagree-

ment prevails are swiftly dismissed. Most issues, when openly aired, produce an agenda of unity.

Washington politicians were astounded the first time the Roundtable took a Washington trip, buttonholing senators, congressmen and agency administrators with rock-solid positions on issues affecting agriculture. Washington was happy to see us united — And we got results.

The same thing happens in Springfield. For example, most problems facing Illinois agriculture demand science-based solutions. Where do we find those answers? Research.

All Illinois agriculture supports boosted agricultural research funding. C-FAR, the Council on Food and Agricultural Research, has been highly successful in increasing Illinois agricultural research funding toward being one of the top ten in the country.

All Illinois agriculture has a stake in the reinvention of Extension. The main thrust has been concerted effort by the Chancellor's Commission, including a cross section of Illinois agriculture working together for solutions.

Roundtable efforts also foster specialized team efforts.

Most obvious has been the sustained team effort by the Illinois Pork Producers Association, the Illinois Beef Association, and the Illinois Farm Bureau to ensure Illinois a growing, thriving, livestock industry. Working together IPPA, IBA, and IFB guided drafting of the Livestock Management Facilities Act, hammered out the regulations, and sought amendments to fine-tune them, letting markets determine who will farm and how, but ensuring a healthful, sound environment. Illinois Milk Producers' Association, Illinois Corn Growers, and Illinois Soybean Association also have pitched in.

A more recent example has been agricultural literacy — efforts to help non-farm people understand where their food really comes from and the challenges farmers face.

Not every problem can be solved by such partnering, but most stand a better chance when agriculture forges a solid alliance.

Working constructively, as partners, we can ensure agriculture's prominent place in our state's future.

Ronald R. Warfield of Gibson City is president of the Illinois Farm Bureau and the insurance and investment companies that make up Country Companies, Illinois Agricultural Service Co., AgriVisor Services, Inc., and the IAA Foundation. In February he was appointed to the Governor's Commission on Property Tax Reform created to focus on reducing the property tax burden for schools and previously served on the Illinois Commission on Education Funding. He holds both a bachelor's and a master's degree in agricultural economics from the University of Illinois, and, along with his family, farms 1,850 acres of corn and soybeans.

There are times when everyone would like a little extra volume to enhance their hearing!

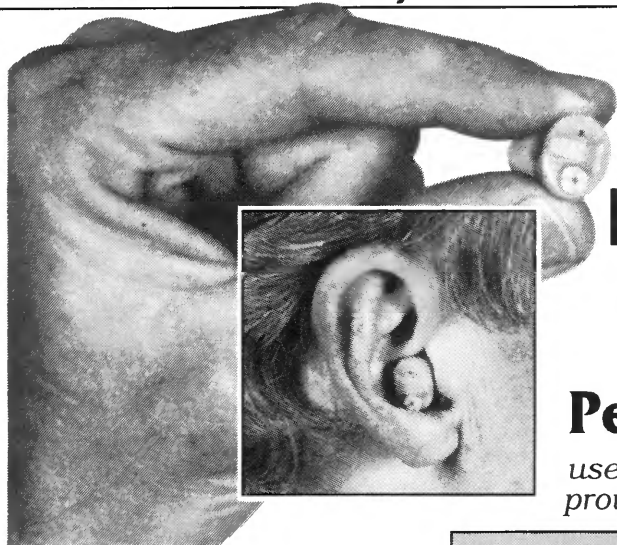

It's So Small It's Almost Invisible

In the Ear... **MaxiSound™** Personal Sound Amplifier

uses sophisticated micro-miniaturized circuitry to provide affordable, in-the-ear sound amplification

by Martin Howard

For the last couple of years, I've constantly had to ask people to repeat what they just said to me... I've turned up the volume on the TV so loud that everyone in the house complains... and my wife and children tell me that I'm speaking too loud.

Naturally, I've denied everything. I didn't want to admit I knew that I was having a slight hearing problem. I was hoping it would go away, all by itself, without doing anything about it! But, deep down inside, I knew I needed a little extra help in the hearing department, and lately, I needed this extra help more and more.

My wife was so tired of me asking her to either speak louder or repeat everything she said. We were having arguments over my hearing. Finally, she insisted that I get some help. She told me to buy a hearing aid.

Sure, just what I need. A bulky, ugly, ill-fitting and heavy hearing aid sitting behind my ear. And, the darn thing will probably rub the skin off my ear too!

She laughed at me. No, it's nothing like that - science and technology have revolutionized the audio industry. The product I'm talking about is called **MaxiSound**. It's a personal amplifier and is very different from the hearing aids you are describing.

MaxiSound is so small and compact that it fits inside the ear canal (it's almost invisible). There are no wires, no behind the ear devices and it doesn't cost a fortune. Not only that, but its super sensitive circuitry is designed to maximize your natural ability to hear sounds*. **MaxiSound** can make speech louder, and the sound is crystal clear, pure and natural.

MaxiSound worked so well for me that I am now marketing them direct to the consumer. And, I know that they'll work for you too! *It's great to be able to hear the TV clearly again.*

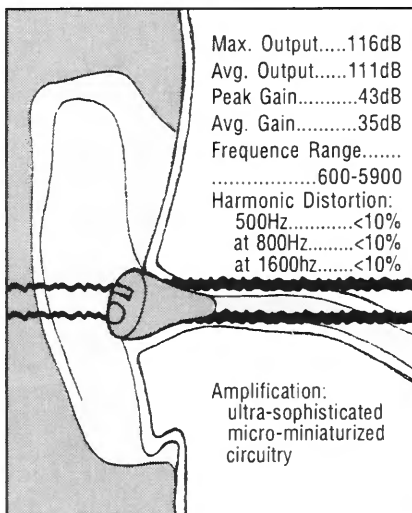

Let me tell you a little more about them. They are ideal for amplification of faint sounds like distant lectures or outdoor wildlife. Each amplifier features an individual on/off and volume control. Its one-size-fits-all is comfortable and comes with a replaceable soft rubber tip, 300 hour battery, cleaning tool, storage pouch and instructions. **MaxiSound** is made in the USA, and is comparable to other sound enhancement systems that retail for up to \$1000.00. Separate maintenance kit includes: 4 replace-

*Not sold for use as a medical device. Consult a hearing specialist if you have a serious hearing problem. Individual experiences may vary depending on severity of hearing loss.

"After seeing your ad in the newspaper, I decided to take a chance on your product. Imagine my surprise when I first tried your sound amplification product and it worked great. The amplification seemed to balance out the hearing between my left and right ear. I am completely satisfied with both the sound quality and amplification of your MaxiSound product."

Dr. George T. Stallings

ment tips, 4 batteries, extra cleaning tool and detailed care instructions.

Your satisfaction is guaranteed or return for a full refund of purchase price (less P&H). Because we work directly with the primary source, you can purchase a pair (left and right) **MaxiSounds** for less than one of our competitor's units. *That's guaranteed.*

COMPARE FOR YOURSELF SEE THE DIFFERENCE

	Most Brands	Crystal Ear	MAXI SOUND
Required fitting	Yes	No	NO
Required testing	Yes	No	NO
Battery life	160 hr	320 hr	300hr
Impact resistance	Average	Excellent	Excellent
Feedback	Frequent	Limited	limited
Telephone use	Yes	Yes	Excellent
Retail price: each	\$1000.	\$299.85	\$149.95
pair	\$2000.	\$599.70	\$279.95

WILLOWS GS, Inc. Dept. MSA- 370
179 Post Road West, Westport CT 06880

©1998, WGSJ

Please RUSH me by UPS the guaranteed **MaxiSound Personal Amplifier(s)** ordered below:

ONE **MaxiSound** unit only **149.95**
Indicate Left Ear or Right Ear
 SAVE! Order a Pair for \$279.95
 Maintenance Kit \$20.00

Add \$10.00 for shipping, handling and insurance per order.

Enclosed is check/M.O. for \$_____ State _____ Zip _____

Charge: VISA MasterCard
 Discover Exp Date ____/____/____

Acct _____

Signature _____

Name _____

UPS Address _____

City _____

State _____ Zip _____

CHARGE ORDERS CALL 1-800-770-1155 9AM to 5PM EST

LOANS TO \$25,000 FOR RURAL/HOME IMPROVEMENTS

- * Barns
- * Horse Walkers
- * Kitchen Remodeling
- * Bathrooms
- * Room Additions
- * Fencing

*Quick Approval, Fixed Rates,
Low Monthly Payments,
Less Than Perfect Credit Accepted*



1-888-811-2297

Anderson™ BEDROOM ORGANIZER

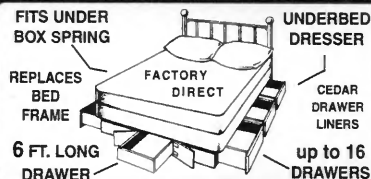

PUT A DRESSER UNDER ANY BED

Increase drawer storage with this beautiful, top quality, solid wood, dust proof, underbed dresser. Fits under any mattress. Shipped UPS
ORDER 48 PAGE CATALOG **605**

1-800-782-4825

KENTUCKY STEEL TRUSS BUILDINGS INC. YOUR SIZE AVAILABLE 1-606-745-0606

24' X 30' X 8'	\$ 3,697
30' X 40' X 10'	\$ 4,997
40' X 60' X 10'	\$ 7,597
50' X 80' X 12'	\$11,997
60' X 80' X 12'	\$14,597
75' X 80' X 14'	\$17,797

**AMERICA'S
BEST
BUY**



ALL STEEL FACTORY PICKUP PRICES *OPTIONS EXTRA*
FARM * COMMERCIAL * RECREATION

UNEARTH GREAT SAVINGS

Geothermal Systems by ClimateMaster



With a geothermal heating and cooling system from ClimateMaster, lowering your heating, cooling and hot water costs will be a snap . . . without sacrificing reliability or comfort.

Working with a specially designed underground earth loop system, a ClimateMaster geothermal unit utilizes the Earth's near constant temperature to exchange energy between the Earth and your home for heating and cooling.

ClimateMaster Geothermal Systems
Designed by the Industry's Most Talented Team

Bauer Comfort Center, Inc.
Cissna Park, IL., 815-457-2589

Bob's Plumbing & Heating
Macomb, IL., 309-833-2315

Bosco Mechanical
Belleville, IL., 618-235-7463

Brooks Heating & Cooling
Columbia, IL., 618-939-3232

Bryan's Heating & A/C
Murphysboro, IL., 618-684-6002

Fowler Heating & Cooling
Marion, IL., 618-997-5288

Garber Heating & Air Conditioning
Morton, IL., 309-266-9372

Jesse Heating and Air Conditioning
Decatur, IL., 217-422-1744
Champaign, IL., 217-352-8511

Read's Heating, A/C & Refrigeration
Olney, IL., 618-393-4102

Sigman Heating & Air Conditioning
Bellville, IL., 618-234-4343

Snell's Plumbing & Heating
Virden, IL., 217-965-3911
Litchfield, IL., 217-324-4560

Thomas Plumbing & Heating Company
Galesburg, IL., 309-343-1101

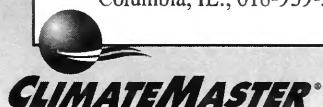

© ClimateMaster 4/98

Or Call 1-888-436-3783 for the Dealer Nearest You!

To learn more about the advantages of geothermal heating and cooling, see us at www.climatemaster.com

Revolutionary "2-in-1" TRIMMER/MOWER™!

Takes the place of both your hand-held trimmer and rotary mower!

- The DR® TRIMMER/MOWER™ rolls light as a feather on two BIG WHEELS!
- TRIMS far easier, better, more precisely than hand-held trimmers. PLUS, MOWS everything from whole lawns (even wet!) to tough waist-high growth with ease!
- Rocks, roots, stumps, etc., do it no harm because the DR® has no steel blades to bend or dull.



- Perfect for ALL mowing and trimming around smaller properties, vacation homes, etc... finish-up mowing and trimming after riding mowers on larger parcels...and rough area mowing everywhere.
- A delight for anyone to use!

"Your machine is all you say it is. 75% quicker than a hand-held trimmer because of the extra power and heavier cord that enables me to wade right thru heavy grass and weeds. There is NO heavy load to swing back and forth tiring your arms and shoulders. It makes weed wacking 'duck soup'!"

--Tom Lawrence, Somerville, New Jersey

"Pound for pound the best piece of equipment we ever bought!"

-- Lloyd Cestare, Perkasi, Pennsylvania

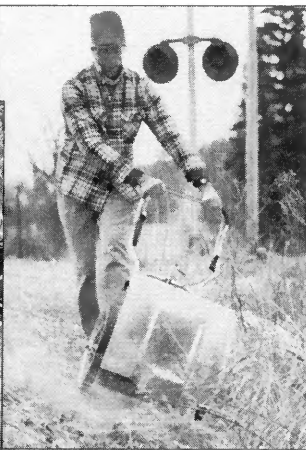

So, WHY HASSLE with hand-held trimmers that are hard to start and tiring to use...OR with small-wheels mowers?

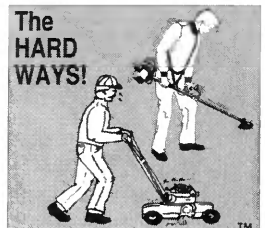

NO MONEY DOWN!
To Qualified Buyers

CALL TOLL FREE
1(800)641-0303

Please call or write for FREE DETAILS about the Revolutionary DR® TRIMMER/MOWER™!

"This is the first trimmer that I can honestly say I enjoy running."
-- Elizabeth Hiller, Topeka, Kansas



YES! Please rush complete **FREE DETAILS** of the Revolutionary DR® TRIMMER/MOWER™ including prices and specifications of Manual, Electric-Starting and Professional Models and "Off-Season" Savings now in effect.

Name _____ WCG
Address _____
City _____ State _____ Zip _____

To: **COUNTRY HOME PRODUCTS®**, Dept. 3779T
Meigs Road, P.O. Box 25, Vergennes, VT 05491

More money for sewers, water

The federal government will invest more than \$8.3 million in five sanitary sewer projects and one safe-drinking water project in Illinois.

Rural Development, an agency of the U.S. Department of Agriculture, reports the money will be complemented by an additional \$51.8 million from other public and private sources.

In announcing the projects, Agriculture Secretary Dan Glickman said the projects would improve the health conditions, living environment and economic opportunities of more than

84,000 people living in economically distressed areas of rural America. Inadequate wastewater disposal is still a major source of water pollution in rural areas. Corroded pipes, outdated waste treatment facilities and sub-standard septic systems all take a heavy toll on the quality of our nation's drinking water supplies, aquatic habitat and recreational waters.

The money, in the form of loans and grants, will help pay for sewer projects in Blandinsville in McDonough County, Parkersburg in Richland County,

Equality in Gallatin County, New Minden in Washington County and Hidalgo in Jasper County. EJ Water Corp. in Effingham County also will receive some of the money to expand.

The USDA says it has loaned more than \$15 billion in the last 58 years. It boasts a loan loss rate of just 1/10 of one percent, or just \$1 lost for every \$1,000 loaned, making it one of the most successful federal lending programs in any area of federal government.

Deer repellent?

Want a sure-fire strategy to deal with deer supping on your sapling? "Try acceptance," suggests a Southern Illinois University senior scientist.

Jack L. Roseberry has "racked up" more than 20 years of research into the ways of whitetail deer at the Wildlife Research Laboratory at SIU's Carbondale campus. He and two new foresters at SIUC agree that nothing much deters deer for long.

"You'll hear people recommending soap or human hair or mountain lion urine — ask 10 people, and you'll get 10 different opinions on how to keep them away," said Roseberry. "I don't think there's any product that really works, because if there were, everybody would be using it."

Foresters John W. Groninger, a Pennsylvania native, and James J.

Zaczek said tree shelters are helpful in some instances, but cost and aesthetics for large-scale planting make them impractical. Even for a single tree planted by a homeowner, shelters tend to over-protect the plant, making them spindly and not very wind-resistant.

Even electric fences pulsing with intermittent current are a short-term solution at best. "After a few years, the deer just fold themselves up and go right through it," said Zaczek. "They don't get shocked every time, and I think they just take the chance."

Instead, it's best to plant an older, taller tree.

"I tell people the magic number is 4 1/2 feet," said Zaczek. "Anything that tall or taller, deer will have a hard time killing because the growing point will be above their browse line."

A recent inventory indicates the deer population in Illinois to be about 800,000, and Roseberry reports that levels are beginning to level off in most counties.

Now, about those rabbits in the garden . . .

Advertisement

Hate Diets? Try Vinegar to Lose Pounds, Inches



Ms. Jeanne Galend

No wonder Ms. Galend is smiling. She found an easy way to lose pounds without pills, diets or calorie counting. Her secret? The healthy vinegar plan. "I dropped 30 pounds so fast it scared me," she writes. Just a few tablespoons of vinegar daily will have you feeling and looking better as you melt away unhealthy pounds. For FREE information packet without obligation, write to: The Vinegar Plan, Dept. FD1861, 718-12th Street N.W., Box 24500, Canton, Ohio 44701. To help us cover printing and postage, \$1 would be appreciated, but not necessary.

©1998 TCO FD0186S02

DRIP IRRIGATION
 Highest Quality, Best Selection, Low Cost!
DripWorks FREE Catalog
Dr. Make It Simple 1-800-616-8321
Custom Pond Liners

Illinois wine study completed

Southern Illinois University has completed a bench-marking study of the state's fledgling wine industry.

The project was co-sponsored by SIU and the Illinois Manufacturing Extension Center, which tries to help small, downstate companies succeed. "The idea wasn't so much to solve problems as to trigger red flags where needed, said Kyle Harfst of SIU.

Harfst said less than 10 percent of all wines produced in Illinois are made with Illinois grapes, and all of the wineries expressed an interest in using grapes for Illinois wines as long as the quality was there. "If growers could supply the varieties they needed, wineries would buy 10,210 more gallons of Illinois grapes this coming season, 16,513 gallons two years from now, and 22,694 gallons three years from now. To meet that third-year demand, we'd need 162 more acres planted to grapes than we have now."

Missouri wineries attract more than 2 million visitors each year, making them the second most popular attraction in that state, right after professional sports in St. Louis and Kansas City, Harfst said. "Increased tourism in Illinois would increase sales, which in turn would build up the industry."

The power of human connections

You may have noticed television commercials now appearing bearing the Touchstone Energy brand in conjunction with the nation's electric cooperatives.

Many of Illinois' 26 electric cooperatives have signed on as partners in the new branding campaign. The Touchstone Energy effort was developed in response to increasing competition in the electric utility industry. Although 1,000 electric co-ops serve 30 million people in 46 states and own and maintain half the nation's power lines, to survive in today's market they must stand out above the rest.



Surveys showed that cooperatives enjoy a unique relationship with their members. Research confirms that co-ops' strongest asset is their ability to be responsive and to provide members a voice in how services are provided. Members also say that co-ops are efficient and contribute enormously to local communities, and that's the message of the Touchstone campaign, with its tagline "The power of human connections."

The idea is similar to other national brands. Like True Value Hardware, you know the local owner, and you recognize the national brand.

New safety program leaves lasting impression

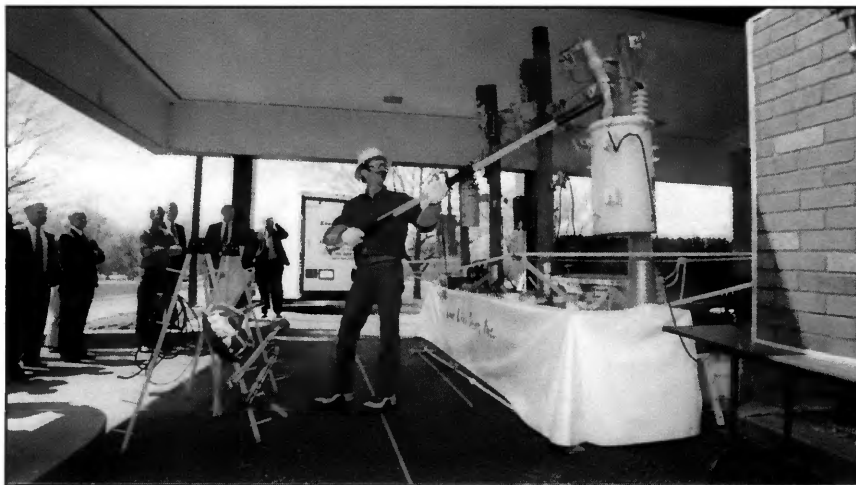

Kyle Finley's display is constructed with real poles, transformers, line hardware – and 7,200 volts of electricity.

A new electric safety program gives live demonstrations to businesses, schools, fire departments, farms, electric companies and cooperatives.

Begun by Kyle Finley, formerly a line-

man with Eastern Illini Electric Cooperative in Paxton, Live Line Demo Inc. uses live electric power to educate the public about proper safety precautions around electrical equipment. It also explains your electric utility's system and how it operates, and demonstrates ways to prevent accidental contact with live wires. The display is portable and can be demonstrated indoors and outdoors.

Finley can be reached at (217) 759-7916 or call your local electric co-op.

**NOT A "ROUND TOP!"
NOT A "POLE BARN!"
100% ALL STEEL**

24x30x9 - \$3459	30x39x12 - \$5034
30x30x9 - \$4160	36x50x12 - \$7145

OVER 130 STANDARD SIZES TO CHOOSE FROM • CALL TODAY FOR FREE INFO

36x60 Shown
Garage/Shop • Boots/RV
Hobby Shop • Horse Barns

Simpson Steel Bldg. Co.
P.O. Box 87
Columbus, KS 66725

DEALER INQUIRIES WELCOMED
Ask About Our Complete Line of Industrial/Commercial Buildings and Mini-Storage!

1-800-959-0220
FAX 316-429-8412

America's Oldest & Largest Rare Breed Hatchery
FREE COLOR CATALOG

Over 140 varieties Baby Chicks, Bantams, Turkeys, Game Birds, Peacocks, Waterfowl, Guineas, Plus Books, Equipment, Eggs, Incubators, & Medicine.

1-800-456-3280
(24 hours a day)

Website: <http://www.mcmurrayhatchery.com>
Murray McMurray Hatchery,
C132, Webster City, Iowa 50595-0458

IN THE PREDAWN

Southern Illinois dusk, a line of vehicles winds its way down narrow, remote roads. The migration, made up mostly of large vans, looks very much like a herd of brick-shaped pachyderms heading for some mysterious elephant graveyard.

But that's not the case at all. Instead, the parade is made up of some 2,000 men and women, heading for Alto Pass and the starting point for the 11th annual River to River Run, which was held this year on Saturday, April 18.

The run, which brings serious

runners and fun joggers together, is serious business in Southernmost Illinois. While some 250 vans were needed to transport runners, there are many more vehicles involved, and gas stations and convenience store sales jump dramatically.

Gordon Pitz, a psychology professor at Southern Illinois University-Carbondale (SIU-C), came up with the idea for the run several years ago. He notes that it came about after he and his club, "River-to-River Runners," had been approached by the local tourism council, who suggested that a mass run might bring dollars into Southern Illinois. They pro-

posed a 10K run or marathon.

"I'd read about a run in Oregon," Pitz says, "called the 'Hood-to-Coast,' which involved a relay from Mt. Hood to the Pacific Ocean, a distance of about 180 miles, and a similar run seemed like a good idea. I suggested a river-to-river run."

In retrospect, it's surprising that people thought it was a silly idea. Even so, Pitz persisted, and he and his wife cruised miles of rural roads, looking for a route. While there's a River-to-River hiking trail, it wasn't viable as a race course, although the original run did use a small part of it.

"It takes an enormous amount of groundwork to get a project like this off the ground," Pitz says, "and if there's one thing I'd tell someone hoping to set up a run, I'd urge them to make careful preparations, and be ready to have to make a lot of adjustments. On our second year, we learned a week before the run that part of our road was underwater, and that a critical bridge on the hiking trail was out."

He adds that working with towns on the way is important, too. "While the race is a boon to towns," he says, "it's also disruptive. And we had to find lots of volunteers to help. That first year, we had 40 or so. Now, there are about 400, and some have been doing it for years. In some places, we just turn over the baton ex-

There was plenty of rural countryside for the runners to enjoy.

Above, it takes some 400 volunteers to make the race run smoothly, and here, retired school teacher Ruth Walker Hume directs traffic through Goreville.



River

Story and photos by Jack Halstead

change locations to a local organization, and they handle it.”

Pitz chuckles at his attempts on that first race, and notes that after the club had decided to try the idea, it had advertised in every running publication they could get hold of, and sent invitations to every club they could find an address for.

“I’d promised the tourism people we’d have 20 teams,” he says, “and we crossed our fingers and hoped for 12. We finally wound up with 60, and we were astonished. We’ve since quit advertising and seeking publicity, because we have more teams than we can handle. We had to turn about 70 teams away this year.”

Teams come from all over the Midwest. Some came from as far away as California and Florida. Some motels throughout the area are booked for the nights before and after the race for a year in advance, and area restaurants and campgrounds do a land office business, too.

Boosters say the race brings some \$200,000 into the area economy, and compares favorably in economic impact to Parents’ Day at SIUC and Graduation Day.

The relay, which ends in Golconda with the kind of festivities usually reserved for the ends of wars, is a particular boon to that small Ohio River town.

Charlotte Anderson, program manager, Main Street Golconda, notes that her organization is involved in economic development for the town. The run, she says, brings several thousand dollars into the community, and she’s hoping to help it snag even more of that money in the future.

“We hope to convince more people to spend at least one night



Bob Reed, a director of Illinois Rural Electric Co., and a Nebo farmer, right, hands over the baton to Glennon Rost of Quincy after running his first of three legs.

in our town. Now, most runners spend the night before and after the race in Marion, Carbondale or Murphysboro, and we hope some of them will spend more time exploring Golconda. Our town has a lot to offer,” she says.

But the people in the wending vans don’t worry too much about that kind of thing. They’re focused on the run, and they’re an interesting blend of different ages, occupations and outlooks.

One team in this year’s race was

“Team Dix,” which is based in Quincy. Jim O’Niell, a Quincy insurance adjuster, heads up the team. Bob Reed, 51, is a Nebo farmer, and a member of the board of directors of Illinois Rural Electric Co., Winchester.

Don Van Houten is field services representative for the Association of Illinois Electric Cooperatives in Springfield. At 53, he was the team’s oldest member. Glennon

Continued on page 12...

to-River Run

River-to-River
continued from page 11...

Rost, 35, is a bank vice-president in Quincy. Ryan Constable, 19, is the youngest member of the team. He installs security systems for his father's business in Hannibal, Mo. Darren Bishop, who works in the shipping department for a department store chain, is 30. Tom Santee, 32, is an executive in a Hannibal factory. Phil Wiegard, 30, is a UPS driver who lives in Quincy and works out of Palmyra, Mo.

Each team has a name, and the names picked range from the indecipherable to the whimsical to the bizarre. Silkworm, a Murphysboro firm, had a team there, and its "Team Worm" wore matching black uniforms with white accents. The "Dozier Tribe" ran, too. John Dozier, a member of the Wayne-White Counties Electric Cooperative board of directors, is patriarch of the tribe. At 74, he doesn't run in the race. But the entire tribe is made up of sons, daughters and grandsons, all Doziers and ranging in age from 19 to 51. The name "Fastor Pastors" left little doubt as to the occupation of that team's members, while SNAROSLA did little to describe the people running with that team. And, We8Dust sug-

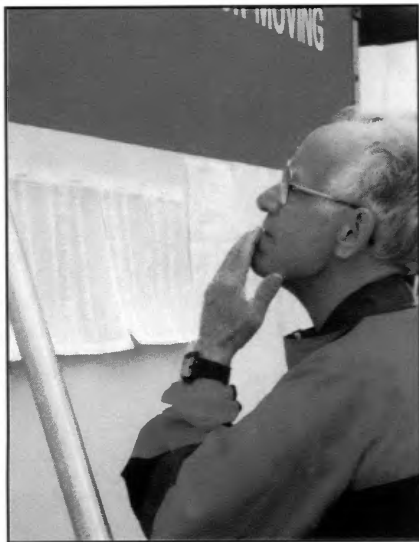

For many, team standings, which were posted at the end of the run, were very important. Here, a man scans the rankings.



At the end of the run, all members of a team, and maybe an occasional hanger-on, all run across the finish line together. Here, Team Dix makes the final sprint.

gests a team with a short winning streak.

Long before dawn, people emerged from their motel rooms and loaded their vans for the trek to the starting line, and two very different types were easily discernible. Some immediately began exercising, as if they begrudged the sleeping time that had cut into their conditioning.

Others dragged weary bodies to vans for the drive to the start. One, rubbing sleep from half-open eyes, looked at an exercising team and grumbled, "It's disgusting how pumped up some people are. I got up so early that I had to pinch myself to see if I was awake, and I still don't know." But most were rarin' to go.

Teams were made up of eight runners each, mostly, and each runner ran three times during the day. If, for some reason, there were only seven members on a team, someone was responsible for running two sets of legs.

In several small towns along the way, and at many houses, small clutches of people gathered to cheer the runners on. Some Southernmost Illinois residents have been doing that for years.

People offered water to runners, and the First Baptist Church of Cobden had set up tables to provide liquids and nutrients to those who were interested.

Although runners couldn't appreciate it much, they ran through some scenic countryside that might well put the Great Smokies to shame. But the scenery offered a mixed blessing, too. Nearly every leg of the race had some uphill in it, and the teams' leaders plotted their strategies carefully. Organizers had broken the entire distance into separate legs, with a profile illustrating each segment's ups and downs. Legs were rated, "Easy, moderate, hard and very hard."

Naturally, runners who run well on hills were assigned to hilly terrain, while others were scheduled to run the level or primarily downhill segments. It was all part of winning for some, or making at least a respectable showing.

And while they were doing that, they were also priming the Southern Illinois economy.

Those interested can call RRR at (618) 453-7200. Or point your web browser to rrr.olm.net

**90-NIGHT
IN-HOME TRIAL!**



**The Only
Mattress
Recommended By
PAUL
HARVEY!**

"After three back surgeries...I thought I would never again have a good night's sleep. Thanks to Select Comfort, I can now look forward to going to bed."

—David D., Lucasville, OH

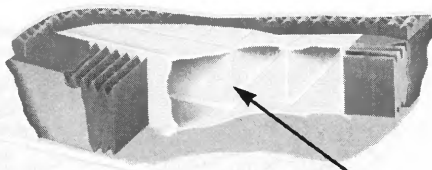

**Patented
Air Chamber
Design!**

Wake Up Energized!

"I have major back problems, and have tried all types of mattresses, including the most expensive waterbed. Select Comfort gave me the best night's sleep I have had in years."

—James C., Moss Point, MS

The SELECT COMFORT® sleep system. It's not just a better mattress, but a better way to sleep. Even back pain sufferers can sleep more comfortably!

The Select Comfort Sleep System doesn't rely on springs or water, but on a cushion of air. Air gently contours to your body's shape, reducing uncomfortable pressure points, and tests show it also helps properly support your back and spine.

*The Mattress with Easy
Push Button Firmness Control!*

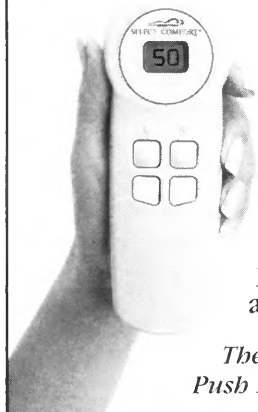

SELECT COMFORT® sleep systems comfortably contour to your body, properly support your back and spine, and reduce pressure points.



Metal coil mattresses can create uncomfortable pressure points and provide uneven support over time.

TRY IT FOR 90 NIGHTS!

We're so sure you'll sleep better on air, you can take up to three months to decide, or your money back. You've got to sleep on it to believe it!

For a FREE VIDEO and Brochure, call now!

1-800-831-1211
Ext. 25212

**Yes! Please rush me a FREE
Video and Brochure.**

Name _____
Address _____
City _____ State _____
Zip _____ Phone _____
Ext. 25212



SELECT COMFORT®

Mail to: **Select Comfort Direct Corporation**
6105 Trenton Lane North, Minneapolis, MN 55442

© Select Comfort Direct Corp., 1998

AROUND YOUR HOME

Protect yourself from consumer fraud



Barbara Cooper

Consumers lose billions of dollars each year because of fraud. Legally, fraud is the intentional misrepresentation of an important fact made to influence the buyer. Consumers are solicited to take part in fraud schemes by mail, telephone or by door to door sales. The newest place to look for fraudulent offers is the Internet. Common swindles include home improvement fraud, sweepstakes and free prize offers, work-at-home schemes, travel offers, credit repair offers, investments, charities and 900 phone numbers.

Con artists tend to target older citizens. According to some research from Eastern Michigan University, elderly victims of confidence swindles are more likely to be female, age 65 to 79.

There are some general warning signs of fraud. One warning sign is an offer of something for nothing or free merchandise. You should be suspicious of promises of free prizes or awards; often there are strings attached and fees and other costs that may far exceed the value of the "free" merchandise.

A second warning sign is pressure to act now. In most situations, any legitimate offer that is good today should be good tomorrow. Beware of a sales person who runs down their own merchandise or another seller's merchandise. This technique is usually used to set you up to consider a more expensive good or service.

A fourth warning sign is a contract with vague or tricky wording. Don't sign any contract you don't understand or one with blanks that are not filled in. Take the time to have someone you trust review any legal documents before signing. Be suspicious when the seller's spoken promises are different from the contract.

Barbara Cooper is a consumer & family economics educator at the Springfield Extension Center, Cooperative Extension Service. You may write to her in care of Illinois Country Living, P.O. Box 3787, Springfield, IL 62708. Telephone her at (217) 782-6515 or send e-mail to cooperb@Idea.ag.uiuc.edu.

Beware of exaggerated claims or lavish promises. Remember — if it sounds too good to be true, it probably is. If the seller makes claims that just don't seem likely, check it out before buying.

Several private and public agencies help protect consumers against fraud and may be able to help those who have been victims. The Illinois Attorney General is charged with protecting Illinois consumers against fraud and prosecuting those who practice fraud. If you have a question about a seller or an offer, contact an office of the Attorney General. There are offices in Springfield, Chicago and Carbondale. Your call may also help to warn other consumers.

Another helpful source of information about sellers are Better Business Bureaus (BBB). A BBB keeps track of complaints about sellers and will share that information with consumers. If a business doesn't treat consumers fairly, you won't learn that by calling a BBB if no one has called to complain. BBBs also will work with consumers to resolve complaints against sellers. There are two BBBs in Illinois (one in Chicago and one in Peoria); many consumers in southwest Illinois may also use the services of the BBB in St. Louis. You may also call a BBB in another state if you want information about a seller located elsewhere.

Consumers are their own best line of defense in protecting themselves against consumer fraud. To avoid becoming a victim of fraud, consumers should:

Take time to think through decisions. Get more than one estimate and ask a trusted friend to review the options with them before deciding. Politely but firmly say "no" to situations that appear suspicious. Exercise your consumer rights.

Consumers can also reduce the number of chances sellers have to contact them by removing their names from mail and telephone lists and asking magazine publishers and mail order firms not to sell their names to other marketers.

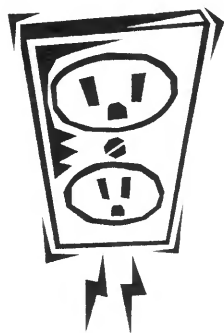

Introduces

AFFORDABLE Long Term Care Insurance

PROTECT YOUR NEST EGG AND YOUR INDEPENDENCE

*Copyright © 1/90 All Rights Reserved

MONTHLY RATES

4-YEAR BENEFIT

MONTHLY RATES

Monthly Benefit	1,800	2,400	3,000	3,600
Maximum Payable	90,000	120,000	150,000	180,000
42	4.59	6.12	7.65	9.18
43	4.59	6.12	7.65	9.18
44	5.10	6.80	8.50	10.20
45	5.10	6.80	8.50	10.20
46	5.10	6.80	8.50	10.20
47	5.61	7.48	9.35	11.22
48	5.61	7.48	9.35	11.22
49	5.61	7.48	9.35	11.22
50	6.12	8.16	10.20	12.24
51	6.63	8.84	11.05	13.26
52	7.14	9.52	11.90	14.28
53	7.65	10.20	12.75	15.30
54	8.67	11.56	14.45	17.34
55	9.18	12.24	15.30	18.36
56	9.69	12.92	16.15	19.38
57	10.71	14.28	17.85	21.42
58	12.24	16.32	20.40	24.48
59	13.26	17.68	22.10	26.52
60	14.28	19.04	23.80	28.56

Monthly Benefit	1,800	2,400	3,000	3,600
Maximum Payable	90,000	120,000	150,000	180,000
61	15.81	21.08	26.35	31.62
62	16.83	22.44	28.05	33.66
63	19.38	25.84	32.30	38.76
64	20.91	27.88	34.85	41.82
65	22.95	30.60	38.25	45.90
66	26.01	34.68	43.35	52.02
67	28.56	38.08	47.60	57.12
68	31.62	42.16	52.70	63.24
69	35.19	46.92	58.65	70.38
70	39.27	52.36	65.45	78.54
71	42.84	57.12	71.40	85.68
72	47.94	63.92	79.90	95.88
73	54.06	72.08	90.10	108.12
74	59.16	78.88	98.60	118.32
75	66.30	88.40	110.50	132.60
76	74.46	99.28	124.10	148.92
77	83.64	111.52	139.40	167.28
78	95.37	127.16	158.95	190.74
79	109.14	145.52	181.90	218.28

LIFETIME BENEFITS ALSO AVAILABLE

Illustrated plan pays for skilled, intermediate, and custodial care. Other amounts available upon request. Premiums are preferred rates with a 90 day elimination period, based on applicants age at issuance of policy. 0, 20, and 60 day elimination periods are also available. Policies are guaranteed renewable for life as long as premiums are paid. Premiums may be paid annually, semi-annually, and monthly bank draft only. No waiting periods for pre-existing conditions. Premiums can increase only if increase applies to all policies in same state and class. However, premiums are guaranteed not to increase for 5 yrs. from effective date of policy. GoldenCare Protector II will not pay benefits for: 1) Treatment resulting from alcoholism, drug addiction or chemical dependency, unless as a result of medication prescribed by a physician; 2) treatment arising out of suicide (while sane or insane); attempted suicide or intentionally self-inflicted injury; 3) treatment provided in a government facility (unless otherwise required by law); services for which benefits are payable, unless otherwise mandated by Federal law, under Medicare or other governmental programs (except Medicaid); services for which no charge is normally made in the absence of insurance; 4) confinement, treatment or services received outside the United States; 5) services rendered by a member of your Immediate Family; or 6) treatment resulting from mental, nervous, psychotic or psychoneurotic deficiencies or disorders without demonstrable organic disease. **IMPORTANT: GoldenCare Protector II will cover qualifying stays or care resulting from Alzheimer's disease or similar forms of senility, senile dementia, or other types of Cognitive Impairment.** Policy form no. GCPRO 2. Rated A (excellent) by A.M. BEST*. Policies underwritten by Bankers United Life Assurance Company, Bedford, Tx, 76021. Established in 1936.

NOT AVAILABLE IN ALL STATES.

*An opinion, not a recommendation.



Bankers United Life
 Assurance Company
 Bedford, Texas

For More Information Call:
(800) 796-0029
 For Priority Service Fax:
(309) 353-6199

Or clip and mail Application Request Form in an envelope to:

REGIONAL OFFICE
 P.O. Box 822
 Pekin, IL 61555-9945

APPLICATION REQUEST FORM

The information you provide will be kept in strict confidence.

NAME _____
 ADDRESS _____
 CITY _____ STATE _____ ZIP _____
 DATE OF BIRTH _____ MALE FEMALE
 MONTHLY BENEFIT DESIRED _____
 HOME PHONE () _____ WORK PHONE () _____
 BENEFICIARY _____
 If a phone conversation is needed, the best time to call me is:
 Morning Afternoon Evening (Home Work)
 I wish to pay premiums: Annually Semi-Annually Monthly Bank Draft
ADDITIONAL APPLICATION(S) REQUESTED FOR:
 NAME _____
 DATE OF BIRTH _____ MALE FEMALE
 MONTHLY BENEFIT DESIRED _____
 COMMENTS _____
 I presently have a LTC policy

GOLDEN CARE PROTECTOR II

I am also
 interested in:

- 0 DAY ELIMINATION PERIOD
- 20 DAY ELIMINATION PERIOD
- 60 DAY ELIMINATION PERIOD
- HOME HEALTH CARE OPTION
- BENEFIT INCREASE OPTION
- RETURN OF PREMIUM OPTION
- PAID UP LONG TERM CARE INS.

Your YARD AND GARDEN

Don't raise mosquitoes in your yard!

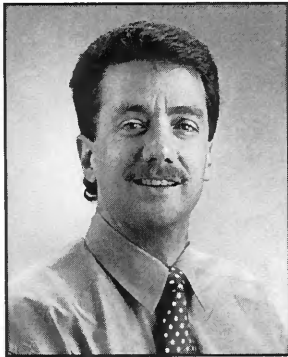

Dave Robson

This year may be classified as the Year of the Mosquito. Or it might not be.

It's hard to predict insect populations year to year. Spring populations are easy to get a handle on due to winter conditions, but spring conditions have an effect on summer populations, summer weather affects fall insects, and so forth. You really can't predict problems for more than one season in a row.

However, warm winter conditions and plenty of spring rains mean mosquito populations may be heavy this summer. Breeding areas are numerous and larvae soon will be hatching.

Mosquito problems in your yard can be reduced by eliminating breeding sites. This is key to any type of mosquito control program. Fortunately, an ongoing program of eliminating these sites in your yard is easy and not very time consuming. However, it must be done regularly.

Mosquito outbreaks, in which large numbers of biting mosquitoes are present for several days, are the result of lowland flooding a couple weeks previously. Eggs laid in these low areas can be dry for months.

Heavy rains flooding these areas cause eggs to hatch, resulting in larvae that develop into adult, biting mosquitoes in about two weeks. If you have ar-

reas of your property flood for at least 10-14 days at a time, adjust drainage so areas drain better or maintain it as a permanent pond to allow you to reduce mosquitoes from these areas.

Permanent bodies of water, such as ponds, abandoned swimming pools, and garden pools should contain top-feeding fish to eat any mosquito larvae that try to develop. *Gambusia*, known as mosquito fish, most bait minnows, or guppies in water bodies will eliminate any mosquito larvae present.

If the water is shallow, the fish may die from heat or freezing and have to be replaced occasionally.

When selecting fish, realize *Gambusia* may be difficult to find since they do not overwinter here, guppies need water at least 60 degrees F. or warmer, and goldfish may not eat enough mosquito

larvae to be effective. Minnows from a bait shop will probably be the cheapest, most available form of season-long mosquito control.

Mosquitoes can also be controlled as larvae in water with insecticides.

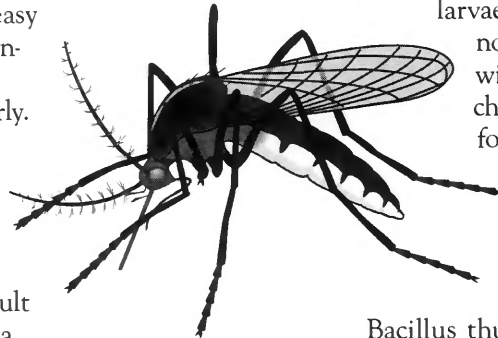

Bacillus thuringiensis israeliensis, a bacterium that kills only the larvae of mosquitoes and closely related insects, is available in some garden centers.

Other mosquitoes will develop throughout the summer in small amounts of water that may accumulate in birdbaths, old tires, tin cans, and other containers lying around the farm. It is essential these areas be managed properly. Removing them is the best.

If you can, get rid of these containers, pierce them so they do not hold water, or empty and dry them at least once a week so mosquitoes are not able to develop in them.

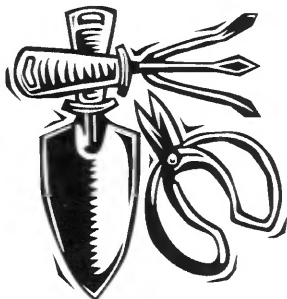

David Robson is an Extension Educator, Horticulture, at the Springfield Extension Center, Cooperative Extension Service, University of Illinois. You can write to Robson in care of Illinois Country Living, P.O. Box 3787, Springfield, IL 62708. Telephone: (217) 782-6515. E-Mail: robsond@idea.ag.uiuc.edu

“A little land—a lot of living!”

Live better on less—with the “Have-More” Plan!

Some people think they have it all, but “the good life” still eludes them.

The answers they're looking for might be in this book...

Millions of today's Americans are stressed. They're frustrated by lack of time and money. They have plenty... but something's missing. They would love to escape from the rat race, if only they knew how...

If you're one of these unhappy people, and all the new books on simplifying life seem to lack something, look into an old book with practical solutions to modern anxieties: *The “Have-More” Plan*, by Ed and Carolyn Robinson.

Written in the 1940s, it was revived to enchant, inspire and instruct a new generation of people who want to take charge of their own lives and *live better*.

Find greater independence and security

One key is growing your own food. You'll know it's fresh and free of pesticides, it tastes better and costs less. But equally important, it puts you in control of *The Good Life*.

It's also fun, and this book will show you how easy it can be, too!

Providing food is only a small part of what “modern homesteading” is about, but you'll find it *all* in this book.

You can simplify your life, spend less and *Have-More* with the help of *The “Have-More” Plan*—and COUNTRYSIDE, the magazine that starts where the book leaves off and brings homesteading into the 21st century.

Ordinarily, *The “Have-More” Plan* costs \$9.95. But it's yours FREE when you subscribe to COUNTRYSIDE. And with this special offer you'll also save over \$3 off the regular subscription price!



First published in the 1940s, this classic has changed tens of thousands of lives. Now this authentic reprint can improve *your* life in the 21st century!

Yours FREE when you subscribe to COUNTRYSIDE... with special savings!

The “Have-More” Plan was written for people exhausted by the Great Depression and World War II. Today it's treasured by those who are burned out by mounting debt, job or retirement insecurity, the dizzying pace of life, and the knowledge that life could be better.

If you like the book, you'll love the magazine!

Like *The “Have-More” Plan*, COUNTRYSIDE is no newcomer, and it too is as pertinent today as it was years ago. COUNTRYSIDE is “82 years old, and a new wrinkle with every issue!”

When you subscribe you'll get six big 100-page issues covering every imaginable aspect of “have-more” living on a few acres or a suburban lot. Grow and preserve food, enjoy country cooking, even raise animals on a small scale! You'll learn time-saving, money-saving tricks to help with home maintenance, gardening, and managing your finances—and your life.

Best of all, you'll read about people just like you who are enjoying a simpler, more productive, more satisfying lifestyle. Learn how you can join them. Order your subscription and free book today!

The Countryside Guarantee: If you're not satisfied with COUNTRYSIDE for any reason, just tell us and your payment will be refunded... but *The Have-More Plan* is yours to keep!

Order now and save \$12.98!

1 year of COUNTRYSIDE	\$18.00
<i>The “Have-More” Plan</i>	\$9.95
Total value:	\$27.95

Pay only \$14.97!

YES, I want to know more about living better with less!

Please enter my 6-issue subscription to COUNTRYSIDE and send me *The Have-More Plan* at no additional cost.

\$14.97 enclosed

Name

Address

City state zip

For Visa/MasterCard orders call 1-800-551-5691 or fax 715-785-7414. e-mail: csymag@midway.tds.net
Visit our web site at www.countrysidemag.com



Countryside magazine
W11564 Hwy. 64
Withee WI 54498

Today's

TECHNOLOGY AND YOU

New dryers need no outdoor vent

Q: *I need a new clothes dryer. Now, the clothes take a real beating and come out wrinkled and tangled. How effective and efficient are the no-outdoor-vent designs and what new features should I consider? -S. B.*

A: Using a no-outdoor-vent clothes dryer design (common in Europe) can reduce many indirect energy costs of running a typical outdoor-vented dryer. Most no-vent models use many surgical stainless steel parts and they can literally last a lifetime. Since no outdoor venting is needed, these dryers can be located anywhere in your house, even in a closet.

A clothes dryer is a major household electricity consumer. Not only does it use energy to heat the air that dries your clothes, but it sucks already-heated or cooled air out of your house for a double energy expense. Outdoor vent covers are typically very leaky and may be a source of bugs and allergens inside your home.

By keeping the dryer heat indoors in the winter, the heating load on your furnace or heat pump is reduced. In the summer, the air-conditioning load from the extra heat is offset by the elimination of hot humid air infiltration. Remember, in the summer, run your clothes dryer late at night or very early in the morning to minimize the peak electricity demand.

Instead of drawing heated air through the clothes and venting it outdoors, a no-vent dryer uses a simple condensing process to dry the tumbling clothes. Air inside the dryer is heated and circulated through the damp clothes. Since it is warm air, it absorbs moisture from the clothes as it dries them.

This warm damp air now circulates through a small heat exchanger built into the base of the dryer cabinet. Another small quiet fan draws room air in through separate passages in the heat exchanger. The two air flows do not mix and no conditioned indoor air is lost outdoors.

James Dulley is a mechanical engineer who writes on a wide variety of energy and utility topics. His column appears in a large number of daily newspapers.

Copyright 1998 James Dulley

This room air cools the warm damp dryer air causing the moisture to condense into a tray. This dryer air is reheated and circulated through the tumbling clothes again to absorb more moisture. When the clothes are dry, you slide out the water tray and empty it. It is basically distilled water that you can use on your plants. For greater convenience, install a tube kit to run the condensed water to a drain.

Another drying option is a combination clothes washer/dryer, all-in-one space-saving cabinet (also popular in Europe's smaller homes). Most use the no-vent condensing drying process. These are very convenient to use. You put in dirty clothes and take out clean dry clothes an hour or two later.

The key to energy efficient and wrinkle-free clothes drying, in a no-vent or conventional vented dryer, is not over drying the clothes. Generally, use an automatic moisture-sensing cycle instead of a timed cycle for the best results.

A reversing-rotation drum (typically reverses direction every several minutes) is another feature that reduces wrinkling and provides fast uniform drying. After the clothes are dry, a "wrinkle-out" option tumbles them briefly every few minutes, for up to an hour, until you have time to remove them.

Another efficiency and convenience option is a super-large (100 load) lint basket. This can reduce inefficient air flow resistance through the dryer when you forget to empty it regularly.

Also, to reduce your drying electricity costs, do loads consecutively to take advantage of the residual heat in the dryer. Separate your clothes and do not add wet clothes to a partially dried load. This can trick the moisture sensor into over drying the clothes.

Write for Utility Bills Update No. 823 - buyer's guide of the most efficient no-vent, standard-vented dryers and combination washer/dryers, moisture sensors, drum rotation, features, prices and efficiency tips. Please include \$2 (with checks payable to Jim Dulley) and a business-size SASE. Mail to: Jim Dulley, Illinois Country Living, P.O. Box 3787, Springfield, IL 62708. To instantly download, go to <http://www.dulley.com>.

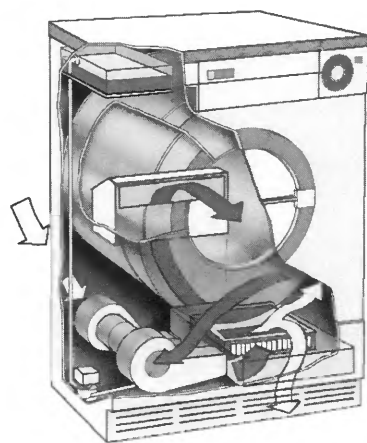

Are you over 55?

"Look What Seniors Can Get Free!"

Washington DC (Special) Are you over 55... or have a loved one who is? Then you'd better take a close look at this!

Every year Uncle Sam gives away hundreds of millions of dollars in cash, goods, and services to people just like you.

Better yet, many of these goodies are available to you regardless of your income or assets!

All this free stuff is one of America's best kept secrets... simply because the government doesn't advertise that it's available.

Now, an amazing new book reveals thousands of sources of fabulous freebies which are yours for the asking. Entitled "Free for Seniors", you'll learn all about such goodies as how you can:

- ▶ Get free prescription drugs. (This one alone could save you thousands of dollars!)
- ▶ Get free dental care... for yourself AND for your grandkids.
- ▶ Get up to \$800 for food.
- ▶ Free legal help.
- ▶ How to get some help in paying your rent, wherever you live.
- ▶ How to get up to \$15,000 free money to spruce up your home!
- ▶ Here's where to get \$1,800 to keep you warm this winter.
- ▶ Here's how to get help in paying your electric bill.
- ▶ Access the very best research on our planet on how you can live longer.
- ▶ Are you becoming more forgetful? Here's valuable free information you should get now.
- ▶ Stop high blood pressure and cholesterol worries from ruling your life.
- ▶ Free help if you have arthritis of any type.
- ▶ Incontinence is not inevitable. These free facts could help you.
- ▶ Free eye treatment.
- ▶ Osteoporosis: Learn about the causes, risk factors and new treatments.

▶ Depression: Being down in the dumps is common, but it doesn't have to be a normal part of growing old.

▶ Free medical care from some of the very best doctors in the world for Alzheimer's, cataracts, or heart disease.

▶ New Cancer Cure? Maybe! Here's how to find out what's known about it to this point.

▶ Promising new developments for prostate cancer.

▶ Get paid \$100 a day plus expenses to travel overseas!

▶ How to get your own VIP tour of the White House without waiting in line with everyone else.

▶ Up to \$5,000 free to help you pay your bills.

▶ Free and confidential help with your sex life.

▶ Impotence? Get confidential help... Free therapies, treatments, implants, and much more.

▶ Hot Flashes? This new research could help you now!

▶ Find out if a medicine you are taking could be affecting your sex life.

▶ Enjoy visiting our National Parks? Here's how you can get paid to spend your summers there.

▶ How you could travel the world... all at government expense.

▶ How to get \$7 off your phone bill each month.

There's more! Much, much more, and "Free for Seniors" comes with a solid, no-nonsense guarantee. Send for your copy today and examine it at your leisure. Unless it makes or saves you AT LEAST ten times its cost, simply return it for a full refund within 90 days.

Where else can you get an investment which guarantees a ten-to-one return?

It's easy to get "Free for Seniors". All you have to do is send your name and address along with a check or money order for only \$12.95 plus \$2 postage and handling (total of \$14.95) to:

FREE FOR SENIORS, Dept. FS7041, 718 - 12th Street N.W., Box 24500, Canton, Ohio 44701.

You may charge to your VISA or MasterCard by including your card number, expiration date, and signature. For even faster service, have your credit card handy and call toll-free 1-800-772-7285, Ext. FS7041.

Perhaps you're asking, "If seniors can get this information free... why is there a charge for the book?"

It's no secret that all the programs listed in "Free For Seniors" can be found for no charge through the hundreds of government agencies, libraries and local senior organizations if you know exactly what benefits are available, what office to contact, and exactly what information to ask for.

Unlike "Free for Seniors," few books or organizations compile ALL these listings into one easy-to-find reference guide, thus saving you an enormous amount of research time finding each individual program.

Research and printing is expensive, so "Free For Seniors" is simply a small price to pay for one complete listing of these hundreds of fabulous freebies!

Want to save more? Do a favor for a relative or friend and order 2 books for only \$20 postpaid.

Call or send for "Free for Seniors" right away and you'll also receive 4 National Institute of Health Special Reports On Arthritis, Sleep, Memory Loss, and Foot Care FREE!

These free reports are limited in quantity and will be sent on a first come, first served basis. You must respond right now to be sure of getting your copy.

Why not do it right now while you're thinking of it? ©1998 TCO FS0167S

<http://www.trescoinc.com>

SAWMILL \$3795.

FREE INFORMATION
Norwood Sawmills
90 Curtwright Dr., Unit 3
Amherst, N.Y. 14221
1-800-661-7746



FREE HEARING CATALOG!

- 45 DAY TRIAL
- \$199 & UP
- BETTER HEARING**

DEPT B34, Brookport, IL 62910
1-800-320-3300 EXT B34

“I make more profit from a 1/4 acre greenhouse ...than from 100 acres of row crops!”

— Jeff Balduff, farmer and greenhouse vegetable grower

You Can Too! Begin a profitable alternative to conventional agriculture! Diversify your farm income! Enjoy a more dependable and consistent cash flow!

Farmers and land owners, just like yourself, are increasing their income dramatically growing high value specialty crops like tomatoes, cucumbers, lettuce, and herbs, year 'round, inside climate controlled, energy efficient greenhouses! With the use of soilless PERLITE growing methods, yields are increased and quality is superior, without the use of harmful pesticides and herbicides! You'll be producing out of season too, when prices are highest!



Request our **FREE Greenhouse Farming Information Pack** and you'll find out how to choose a properly designed greenhouse and growing system for controlled environment vegetable farming!

In addition, you'll learn about our **Grower Technical Assistance Program, Grower Training Workshops, Training Videos, Grower's Manual, Newsletters, Annual Conference,** and other resources valuable to greenhouse farmers!

CropKing Inc. 5050 Greenwich Rd.,
Dept. WG/IL, Seville, OH 44273
Phone 330-769-2002 • Fax 330-769-2616

YES! Send me your **FREE** information on greenhouse farming and tell me how to get the **FREE** video!

Name _____
Street _____
City _____
State _____ Zip _____
Phone (_____) _____ WG/IL1097

FREE VIDEO OFFER!

Call or write today and we'll show you how to get your **FREE*** information packed video, "Your Future in Hydroponics"!

*\$8.50 shipping/handling charge.

Backyard Shops

Steel Buildings

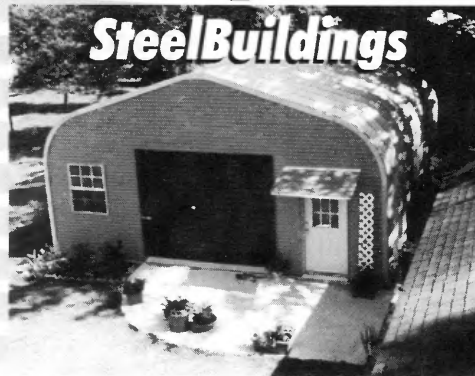

Spring Inventory Sale

Save up to 60%

SAVE ON SELECT SIZES
25X34 • 30X46
40X56 • 50X116

- America's #1 Arch-Type Manufacturer
- 20 Year Warranty • Easy Financing Available
- Easy Do-It-Yourself Construction
- Free 16 Page Brochure



Save Thousands
Call Today **1 800 222-6335**

MOBILE HOME INSULATED ROOFING

STOP LEAKS FOR GOOD

HIGH R-RATED RIDGED INSULATION

NEVER SEAL COAT YOUR ROOF AGAIN

MAINTENANCE FREE

ELIMINATES NOISE

ADDS BEAUTIFUL PROTECTION

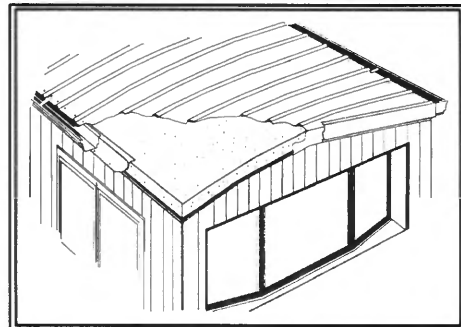

MENTION THIS AD FOR
FREE GUTTERING

OVER 11 YEARS
IN BUSINESS

800 333 9562

FINANCING AVAILABLE WITH APPROVED CREDIT

An Important Announcement to Illinois Homeowners with Equity . . .

What Would You Do With An Extra \$3,600 to \$12,000 per year?

How to Get a Fast Mortgage Loan To Pay Off All Your Bills** (Even If You've Been Turned Down By A Bank Or Mortgage Company)

Rockingham, N.C. - Ray and Becky were frustrated. They'd bought the house 12 years ago and it was five years old when they moved in. Becky laughed out loud when she thought back to that time. Back then it seemed so big and beautiful. But now, 12 years and 3 kids later, the house felt small and run down. The house needed a new roof and her two youngest girls, Emily and Katie, were doubling up in the small 10 x 12 bedroom. Five years ago, Ray and Becky had a contractor come and talk to them about a new addition. Becky remembered how excited she and Ray both were. They even paid to have the plans drawn up. But that was the year before Ray lost his job at the plant. She poured herself another cup of coffee and recalled how depressed they both were. It was over a year before he got another job. And during that time, they got behind on everything.

No Summer Vacation

They were so strapped for money one summer, they couldn't even take Emily and Katie to the beach for a few days for their annual vacation. Sure they finally got all caught up when Ray went back to work, it took them two years and by that time it had ruined their previously perfect credit record, it was a vicious cycle. You know, getting paid on Friday, sitting down on Saturday to pay bills and running out of money before all the bills are paid.

"I Hit A Brick Wall"

After they got caught up they tried again to borrow the money for the addition. First they got turned down by the local bank, then a mortgage company in town rejected them. They just kept hitting the same brick wall. Even though Ray had gone back to work in another carpet mill making MORE money, the late payments that showed up on his credit reports scared the local banks and mortgage companies away. Ray felt like he was working JUST to pay his monthly bills and doing nothing for himself, Becky or the kids. Then he ran into Harvest Mortgage Company. Harvest helped him get a loan to pay off all his bills and consolidate everything into one single payment that was \$358 lower than he had been making. That saved him a whopping \$4,296 per year, TAX FREE. In the first year, that was enough money to close in the back porch, AND enough left over for new bikes for the kids.

Home Equity is the Key



Carole Eskew, Sr., V.P.

"If you have a minimum of 20% equity or more, there's a good chance we can help you save a lot of money every month by combining old bills and your old mortgage into one

new and much lower payment. Or, we can help you get cash out of your home to buy a vacation home, start a business, whatever."

Compare your budget to this:

Amt.	Owed	Payment
\$12,000	2nd Mortgage	\$200. ⁰⁰
8,500	Auto Loan	375. ⁰⁰
2,000	VISA	100. ⁰⁰
2,000	MasterCard	100. ⁰⁰

\$25,000 Current Payment \$775.⁰⁰

-After Harvest Mortgage -

New Payment: \$187.⁸²/mo.

APR 9.077% / 30 yr. term

You Save: \$587.¹⁸/mo., \$7,046.16/yr.

** Rates subject to change*

"I couldn't believe it. We closed our loan 9 days after the first day I talked to them on the phone."

Debbie C., Dallas

"We ended up paying off all our bills and rolling them all into one single payment. After we did, our total monthly payments dropped by almost \$400 per month."

Billy and Judy., Columbus

"Thanks to you and your great company, we feel reborn. Words can not express the relief we feel. We are so glad this battle with the bills is almost over."

James and Laurie C.

Recent Loans Include:

- A \$45,000 loan to a borrower in bankruptcy.
- A \$100,000 loan to a borrower who couldn't verify income through tax returns.
- A \$95,000 bill-consolidation loan that saved the borrower over \$8,100 per year and a whopping \$124,000 over the loan period.

(No singlewides, please)

No Ivory Towers

"When you apply for a loan at Harvest Mortgage, your loan request is reviewed and decided upon by the people right in our office," says a Harvest executive. He added, "Since we are direct lenders, we don't send the information to some guys off somewhere in New York or California. We review and approve loans right here in town locally."

Fast Approval and Closing

That means we can get your loan closed in a matter of days, and you never have to go out of your living room until you're ready to close."

Loan For Purchase or Refinance

Harvest Mortgage officials report that whether you are buying, refinancing a house, just looking to consolidate some bills, get cash for your property, they have created programs to give you the money you're looking for.

Different loan programs include:

- Loans to Borrowers with good credit, with the most competitive rates in the country. These are available for purchasing a new home or refinancing.
- Loans to borrowers with a lot of equity homeowners who have slow credit or have even been bankrupt.
- Cash out loans for investment property with a lot of equity.
- Loans for borrowers who want to do additions or remodel their homes.

Check This Out For Free

To see how much money you may be able to get and exactly how much your payments would be, you can check it out by just picking up the phone and calling us. Be sure to ask for Carolyn Reid at 1-800-554-1314. All of this doesn't cost you a dime, so you owe it to yourself. Don't put this off any longer. Do it now while you're thinking about it! You have got nothing to lose and everything to gain. Call Now!

Harvest Mortgage Company Inc.
Mortgage Bankers

Illinois Residential Mortgage Licensee

**Subject to Qualification

1-800-554-1314

Illinois' FINEST COOKING

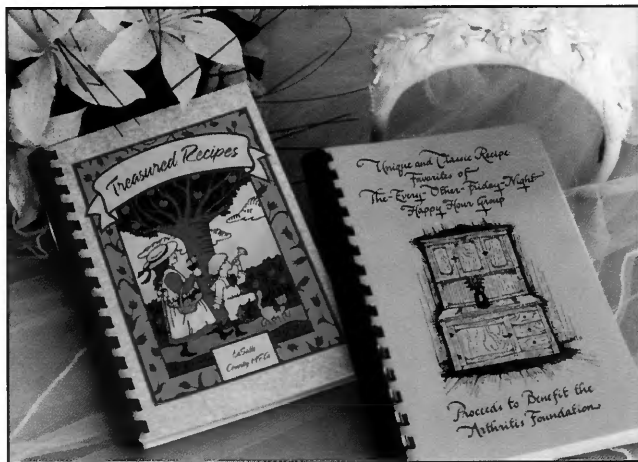

La Salle County Homemaker's Extension Association shares its 1996 cookbook this month. The 172-page plastic ring bound book can be purchased for \$6 plus \$2 postage. Order from Sheila Thomas, 1848 N. 24th Road, Grand Ridge, Illinois 61325. Her phone number is (815) 434-7084.

Originally strictly social in nature, the Every-Other-Friday-Night-Happy-Hour-Group became a fund raising arm of the McLean County Branch of the Arthritis Foundation. The group began in May of 1986. The 1996 cookbook is plastic ring bound and has 121 pages of recipes and can be purchased for \$7 plus \$2 postage. Contact Karen K. McCarey, 1506 N. Center Street, Bloomington, Illinois 61701 or phone (309) 829-1902.

La Salle County Homemaker's HEA

ORIENTAL SALAD

Juanita Sonderoth

1 lb. bag coleslaw mix or chop your own
1 bunch green onions, chopped

2 to 3 oz. pkg. almonds, slivered and toasted
2 pkgs. Ramen oriental noodles
3/4 C. oil
1 T. sugar

Cook noodles as directed on package. Cool and chop a little. Toss noodles, slaw and onions. **Dressing:** Mix oil, sugar and seasonings from noodles. Make dressing ahead so flavor is better. Just before serving, toss slaw with the dressing and almonds.

LIGHT FETTUCCINE ALFREDO SAUCE

Sandy Phalen

1 1/3 C. skim milk
2 tsp. flour
3 slices fat free Swiss cheese
2 sm. garlic cloves, minced
2 T. fat free cream cheese

3 slices fat free American cheese, cut into cubes
1 T. plus 2 tsp. Molly McButter sprinkles
4 C. hot cooked fettuccine noodles

In medium saucepan, on high, add first 4 ingredients. Whisk to a boil. Reduce heat; simmer until thickened. Add cheese; whisk until blended; stir in Molly McButter; pour over fettuccine. Garnish with parsley flakes.

TATER CRISP CHICKEN

Ester Hagie

Place 1 cup Hungry Jack mashed potato flakes and 1 tsp. salt in a plastic bag. Rinse chicken pieces (cut up frying chicken) in cold water, then shake in the plastic bag. Place chicken in 1/4 C. melted butter in 9x13-inch pan, skin side down. Bake at 400° for 1 hour, then turn once after 30 minutes. If desired, add more salt.



BLENDER CREPES

Marie Capatani

1 C. milk
1 C. water
2 C. flour

4 eggs
1 tsp. salt
4 T. melted butter

Blend and let rest for 2 hours or more before using.

RHUBARB-STRAWBERRY UPSIDE DOWN CAKE

Darlene Hettel

- | | |
|---|----------------------|
| 3 C. rhubarb, cut into 1-inch pieces | 1 3/4 C. sugar |
| 1 (10-oz.) box frozen strawberries (juice and all or fresh) | 1/2 C. butter |
| 1 1/2 C. miniature marshmallows | 2 eggs |
| | 1 3/4 C. flour |
| | 1/4 tsp. salt |
| | 3 tsp. baking powder |
| | 1/2 C. milk |

Preheat oven to 350°. Combine rhubarb, berries, marshmallows and 3/4 C. sugar. Place in 9x13-inch buttered pan. Cream 1 C. sugar and 1/2 C. butter. Beat in eggs until light and fluffy. Sift dry ingredients and add alternately with milk to the creamed mixture. Spread batter over fruit and bake for 45 minutes. Serve warm or cold with whipped cream.

Calling all cookbooks!

Is your church or community organization selling its own unique cookbook filled with the favorite recipes of cooks in your area? If you are a cooperative member, send a copy of your book to: Elayne Rhodes, Illinois Country Living, P.O. Box 3787, Springfield, IL 62708, and we will feature your book in the future. Please provide the name, address, and daytime phone number and electric cooperative of the person we should contact for more information.

The Every-Other-Friday-Night-Happy-Hour-Group

DEVIL'S DIP

Debbie Grant

- | | |
|-------------------------------|-----------------------|
| 1 C. sour cream | 1/8 tsp. liquid smoke |
| 1 (4 1/2 oz.) can deviled ham | 1/4 tsp. salt |
| 5 tsp. horseradish | Crackers or chips |

Combine all ingredients (except crackers or chips); blend thoroughly. Refrigerate 1 hour.

ITALIAN WEDDING SOUP

Linda Miller

- | | |
|------------------------------|---|
| 1 lb. ground beef | 1/2 box pastina (teeny-teeny-tiny star pasta) |
| 1 lg. can chicken broth | Fresh Parmesan |
| 1 box chopped frozen spinach | |

Roll and make tiny meat balls; fry and drain. Set aside. In a large pan, add chicken broth with some water to dilute; add spinach and pastina. Boil and add meatballs. Add fresh Parmesan on top of each bowl to garnish.

POTATO WRAPS

Brian Butterfield

- | | |
|---|---|
| 4 small new potatoes (1 1/2-inch diameter each) | 1/4 tsp. crushed bay leaves |
| 1/2 tsp. each Lawry's seasoned salt and pepper | 8 slices bacon, cut in halves crosswise |

Preheat oven to 400°. Wash potatoes and cut into quarters. Sprinkle each with a mixture of seasoned salt, seasoned pepper, and bay leaves. Wrap 1 bacon piece around each potato piece. Sprinkle with any remaining seasonings. Place in baking dish and bake, uncovered for 20 minutes or until bacon is crispy and potatoes are cooked through. Drain on paper towels. Serve with sour cream and chives, if desired.

EASY BREAD

Patti M. Popejoy

- | | |
|-----------------------------|----------------|
| 2 cans Hungry Jack biscuits | Poppy seeds |
| 1 1/2 sticks oleo | Parsley flakes |
| Seasoned salt | Onion flakes |

Melt 1/2 stick oleo in Bundt pan on top of stove at low heat. Sprinkle seasonings and flakes in bottom of pan and mix. Evenly arrange biscuits in pan by standing them on their sides. Melt remaining oleo and pour over biscuits. Bake at 400° for 15 minutes. Let stand 5 minutes after removing from oven. Put plate on top and turn upside-down.

PECAN BUTTERSCOTCH BREAD

Sharon Craig

- | | |
|---------------------------------|------------------------------|
| 1 egg, beaten | 3/4 tsp. baking soda |
| 1 C. brown sugar, firmly packed | 1/2 tsp. baking powder |
| 1 T. butter, melted | 1/4 tsp. salt |
| 2 C. flour | 1 C. sour milk or buttermilk |
| | 1 C. pecan meats, broken |

Combine egg, brown sugar, and butter. Add dry ingredients. Add milk and nuts. Put in greased bread pan. Bake at 350° for 45 minutes.

APRICOT CHEESE DELIGHT

Karen K. McCarey

- | | |
|---|-------------------------------|
| 2 (17 oz.) cans peeled apricots, drained and cut fine | 2 pkg. orange Jell-O |
| 1 (20 oz.) can crushed pineapple, drained | 2 C. hot water |
| | 1 C. combined fruit juice |
| | 3/4 c. miniature marshmallows |

Topping:

- | | |
|----------------------|-----------------------|
| 1/2 C. sugar | 2 T. butter |
| 3 T. flour | 1 slightly beaten egg |
| 3/4 C. grated cheese | 1 C. whipped cream |
| 1 C. juice | |

Drain and save juices. Chill fruits. Dissolve jello in boiling water. Add 1 C. juice. Fold in fruit and marshmallows. Chill until firm and spread with topping. **Topping:** Combine sugar and flour. Blend in egg. Gradually stir in juice. Cook until thick, stirring constantly. Add butter after it thickens. Cool and fold in whipped cream. Spread on jello and top with grated cheese.

MARINATED CHINESE PORK TENDERLOIN

Marcella Besing

Use 1 whole pork tenderloin.

Marinade:

- | | |
|------------------------|------------------------|
| 1/4 c. soy sauce | 3 T. sherry |
| 1 T. brown sugar | 1 T. honey |
| 1 scallion, minced | 1 garlic clove, minced |
| 1 slice ginger, minced | 1 tsp. 5 spice powder |

Marinate at least 2 hours. Preheat oven to 450°. Roast on rack above pan of water 45 to 50 minutes in a 450° oven. Baste while cooking. Boil marinade and drippings to use for dipping sauce. Horseradish sauce and Chinese mustard also goes well.

LIFETIME TANK COATINGS
 Stop all leaks in steel and concrete — Prevent rust forever. Roof coatings for tar paper, composition shingles, and metal buildings. Anyone can apply all coatings. Fix it once and forget it. Serving Farm & Ranch Since 1950. Let us send you complete information.

VIRDEN PERMA-BILT CO.
 Box 7160IN Ph. 806-352-2761
 2821 Mays St.
 Amarillo, Texas 79114-7160

Make Your Workshop Pay-Off
BIG!
 4-in-One power tool lets you Plane, Mold, Sand and Saw with infinitely variable power feed!

Made in USA!

Call Today for FREE Facts!
1-800-821-6651 ext P92F

Woodmaster Tools, Inc. Dept P92F
 1431 N Topping Ave., Kansas City, MO 64120
www.woodmastertools.com

FREE Poultry Catalog Showing
 All Kinds of Poultry in Color

Over 70 Varieties, Baby Chicks, Exotic Rare Breeds, Fighting Games, Guineas, Turkeys, Ducks, Bantams, MasterCard, Discover & Visa . . . **Write or call today for your copy of this years Big FREE Poultry Catalog in Color.**

MARTI POULTRY CATALOG
 Box 27-7, Windsor, Missouri 65360
 Telephone — 660-647-3156

Arco  

\$Quality Steel Buildings\$
1-800-241-8339

40x60x12.....\$ 8,772
 50x75x10.....\$10,457
 60x100x12.....\$17,589
 60x75x12.....\$13,368
 50x100x12.....\$13,934
 100x100x12 w/column.....\$23,987
 100x150x14 w/column.....\$36,535

F.O.B. plant - All Sizes Available
 Codes may affect prices

We will match any deal with Quality Steel!

3300 Holcomb Bridge Rd., Suite 201
 Norcross, Georgia 30092
 Visit us at our web site • www.arcosteel.com

AFFORDABLE LIFE INSURANCE  **NEW LOWER RATES**

our premier rates - low cost, high quality

Sample Monthly Premiums for Kemper Quick Term 10 and 20 Premier Rate Class
 Premiums and Death Benefit Guaranteed Level for 10 or 20 Years

Issue Age	Male Non-Tobacco						Female Non-Tobacco					
	\$100,000		\$250,000		\$500,000		\$100,000		\$250,000		\$500,000	
	10 yrs	20 yrs	10 yrs	20 yrs	10 yrs	20 yrs	10 yrs	20 yrs	10 yrs	20 yrs	10 yrs	20 yrs
15 to 30	9.31	10.79	15.44	19.14	25.67	33.06	8.53	9.74	13.49	16.53	21.75	27.84
33	9.31	11.05	15.44	19.79	25.67	34.37	8.53	10.01	13.49	17.18	21.75	29.15
36	9.66	11.66	16.31	21.32	27.41	37.41	8.79	10.44	14.14	18.27	23.06	31.32
39	10.79	13.40	19.14	25.67	33.06	46.11	9.57	11.48	16.10	20.88	26.97	36.54
42	12.18	15.83	22.62	31.76	40.02	58.29	10.70	12.88	18.92	24.36	32.63	43.50
45	14.09	19.31	27.41	40.46	49.59	75.69	12.09	14.79	22.40	29.15	39.59	53.07
48	17.05	23.75	34.80	51.55	64.38	97.88	13.92	17.14	26.97	35.02	48.72	64.82
51	20.79	29.75	44.15	66.56	83.09	127.89	16.01	20.36	32.19	43.07	59.16	80.91
54	25.23	38.11	55.25	87.44	105.27	169.65	18.44	24.97	38.28	54.59	71.34	103.97
57	31.32	49.24	70.47	115.28	135.72	225.33	22.01	31.32	47.20	70.47	89.18	135.72
60	39.67	64.21	91.35	152.69	177.48	300.15	27.06	40.02	59.81	92.22	114.41	179.22
63	53.85	-	126.80	-	248.39	-	33.93	-	77.00	-	148.77	-
66	73.52	-	175.96	-	346.70	-	43.67	-	101.36	-	197.49	-

*Rates are guaranteed for 10 years. After the guarantee period, rates increase each year, but the insured may be able to re-qualify for another guarantee period with level rates. File-, 15-, and 20-year guarantee plans also available. Contact your Zurich Kemper Life representative for details.

+No tobacco use of any kind in last 60 months. Tobacco user rates are available with our Preferred and Standard rate classes.

[Kemper Quick Term is non-participating term life insurance to age 95, policy form series S-3225, underwritten by Federal Kemper Life Assurance Company (FKLA), Long Grove, IL 60049-0001. FKLA is one of the Zurich Kemper Life Insurance Companies.]

Affordable Kemper Quick Term Premier rates and fast, easy TeleLife processing from Zurich Kemper Life. Now that's life insurance I can live with!

Name _____

Address _____

City _____ State _____ Zip _____

Date of Birth _____ M ____ F ____ Term Desired? _____

Use Tobacco Any Form? Y ____ N ____

Amount of Insurance Desired? _____

Home Phone _____ Work _____

Best time to call: _____ W ____ H ____

GE FINANCIAL SERVICES, INC.
 P.O. Box 815, Camdenton, MO 65020
 CALL 1-888-206-5334 or FAX 573-346-1183

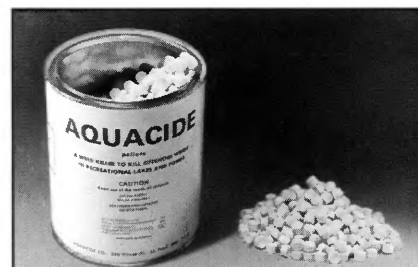

KILL LAKE WEEDS

Proven Aquacide pellets destroy unwanted underwater weeds.

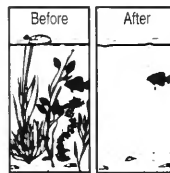

Spread marble sized pellets like grass seed. Effectively kills weeds at any depth.

Registered with Federal Environmental Protection Agency.

Certified and approved for use by state agencies. **10 lb. can** treats 4,000 sq. ft. of lake bottom, \$61.95. **50 lb. carton** treats 20,000 sq. ft. of lake bottom, \$235.00. Prices include delivery charges. State permit may be required. Delivery terms F.O.B. White Bear Lake, MN.

CALL TOLL FREE 1-800-328-9350
 (Except Minnesota Call 612-429-6742)
 Fax 612-429-0563

Or write for free information to:

AQUACIDE CO. Our 43rd year.

1627-9th Street
 Dept. 687
 Box 10748
 White Bear Lake, MN 55110



Don't let lake weeds & algae be a problem!

Contact the professionals • since 1987
Satisfaction Guaranteed

**Free
Estimates**



- Reduce mosquitoes by 75% (proven)
- Call for Do-It-Yourself Kit for small lake owners
- Treat early before you see the problem reduces cost

All chemicals are registered with Federal Environmental Protection Agency.
Irrigate Turf within 24 hours

AQUATIC CONTROL of Illinois, INC.

524 E. 200N Rd • Gibson City, Illinois 60936
Mobil: (309) 635-8444 Office: (217) 784-8808
Toll Free: (800) 759-1100

Licensed and insured by the State of Illinois

**Call
Today!**

Mobile Home

Owners: **ROOF KING**

Mobile Home Super Insulated
Roof Over Systems
40 Year Warranty
Factory Direct From Roof King
1-800-748-0645

GUARANTEED LOWEST PRICES

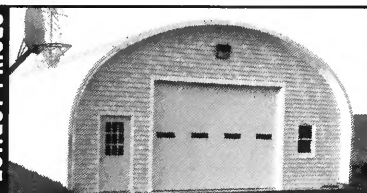

OTHER SHAPES AVAILABLE

BUILD A BETTER BUILDING

FACTORY DIRECT

- Sizes 500-20,000 sq. ft.
- Strongest for Wind & Snow
- Heavy 22, 20 & 18 ga. steel
- Maintenance Free

1-800-668-5422

SALE PRICE

FOR EXAMPLE - 30' X 40'
\$3,688
ENDS OPTIONAL



STEEL BUILDINGS
<http://www.pioneersteel.com>

UNSOLD ORDERS

Singer School Model
Sew & Serge Sewing Machines

Our company placed orders of large quantities of Singer's 1998 model school sewing machines, anticipating large orders. Due to current economic conditions, those orders were not received!

THEY MUST BE SOLD!

These Special heavy Duty School Machines are made with Metal Hooks for years of extended service. All Machines are Now in Factory Sealed Cartons. SINGER'S 25 YEAR LIMITED WARRANTY IS INCLUDED.

SINGER

Manufacturing Quality since 1851

**YOUR
PRICE
\$239.00**

**SUGGESTED
RETAIL PRICE
\$569.00**

COD, AMERICAN EXPRESS, MASTERCARD,
VISA DISCOVER, LAYAWAY WELCOME
"MONEY BACK GUARANTEE"

SINGER SALE

Held By

**Branum's Sewing
& Vacuum Center**

WHAT IS A SEW & SERGE SEWING MACHINE?

#1 - IT IS A SOPHISTICATED SEWING MACHINE... That does Buttonholes (any size), Invisible Blind Hems, ladder Stitching, monograms. Decorative Stitching, Corsetry Stitching, Ribbing, Double Seams, Zippers. Sews on Buttons, Rolled Hems, Darning, Applique, Leather Glove Stitch, Zig Zag, Basting, Blanket Stitch, Pin Tucking, Quilting, and much more. Just turn the dial to see magic.

#2 - IT HAS A PROFESSIONAL SERGING STITCH... It allows you to sew the Seam and Serge the edge of material in one operation. With an optional cutter you can trim the excess material.

#3 - THEY ARE DESIGNED TO SEW ALL FABRICS... Without adjustment, such as Levi's Canvas, Upholstery, Nylon, Stretch Materials, Silk Percalé, Organdy AND...

...THEY EVEN SEW LEATHER!

Now you have it all in one machine
THIS IS A FACTORY AUTHORIZED SALE...

**TO ORDER CALL TOLL FREE
1-800-462-1457**

WIDE as a RIDER!

The DR[®]46 LAWN MOWER combines the speed, power, and width of a rider with the agility of a walk behind!

- BIG THREE-BLADE DECK cuts 46" wide — as wide or wider than most riders!
- Mows over 1.5 acres per hour!
- 4-SPEEDS, POWER REVERSE! 10.5 to 14 HP. Has the POWER to mow overgrown grass with ease!
- PIVOTING MOWER DECK helps eliminate scalping!
- MOWS SLOPES too steep for riding mowers.
- Mows close to trees, fences, and borders, so there's less clean-up trimming to do!
- EVEN MOWS WET, SOFT LAWNS that a rider would sink into and damage!

So, WHY STRUGGLE with a narrow-cutting walk-behind mower... or a cumbersome rider?

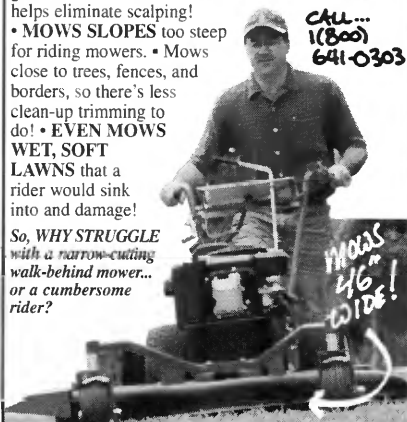

Please mail this coupon TODAY for complete FREE DETAILS of the DR[®]46 LAWN MOWER including prices, specifications of Manual and ELECTRIC-STARTING Models, and "Off-Season" Savings now in effect. There is no obligation.

Name _____ WCG
Address _____
City _____ State _____ ZIP _____
To: COUNTRY HOME PRODUCTS[®], Dept. 3779D
Meigs Road, P.O. Box 25, Vergennes, VT 05491

©1998 CHP, Inc.

Illinois MARKETPLACE

Used meat saws, slicers, grinders, tenderizers and other butchering equipment. 2615 South 1st, Springfield, Illinois. Phone (217) 522-3934.

INSULATION - 4 x 8 sheets, Foil backed foam - factory seconds - easy to install. Contact Ken Nichols at (800) 424-1256.

POST FRAME BUILDINGS-Farm, commercial, residential. Bill Parkinson, Hardin, IL 62047, Phone (618) 576-2287 or (800) 225-8070.

Used and new restaurant and concession equipment. Ice machines, grills, fryers, sinks, poppers, ice cream machines, etc. Erio Sales, 2615 So. 1st, Springfield, IL (217) 522-3934.

WANTED: TO BUY standing timber of all species. Highest possible prices paid. Selective cutting optional. Minimal land disturbance. D&F Logging, Ava, IL (618) 426-3065, (618) 426-9001.

TRAILERS. All types for pickups, horse, stock, utility, cargo, grain, utility-dump. 75-100 in stock. Rawlings Trailer Sales, Hopedale, IL (309) 449-3309.

WATER CONDITIONER with no salt, no maintenance, no electricity, no replacement parts. Call (800) 500-3303, Tower Hill, IL. Ask for Bob.

WORK CLOTHES

GOOD CLEAN Rental-type work clothes, 6 pants and 6 shirts to match \$29.95. Lined work jackets-\$9.95. Satisfaction Guaranteed! Send sizes with check or money order plus \$5-S&H to: WALT'S WHOLESALE, P.O. Box 208-E, Darlington, SC 29532. or MC/Visa orders (800) 233-1853.

LLAMAS ARE WONDERFUL! They do it all - guard livestock, carry your load, give you the wool off their backs, walk with you or pull you in a cart, and are just a joy to be around! Find YOUR ideal llama today at Tranquility Llamas, Bloomington, Illinois. (309) 963-4553.

MAGNETIC THERAPY is reported by many to give relief from: pain, migraine, headaches, allergies, arthritis, etc. (800) 500-3303, ask for Bob.

BASKETWEAVING, CHAIRSEATING SUPPLIES, OAK Baskets, Books, Kits. Quality. Discounted. Retail. Wholesale. Catalog \$1. Ozark Basketry-REN, Box 599, Fayetteville, ARK 72702-0599.

PLAY GOSPEL SONGS by EAR! Add Chords, Piano, Organ. 10 easy lessons \$7.50. Guaranteed. Davidsons, 6727R1 Metcalf, Shawnee Mission, Kansas 66204.

ATTN: CISTERN & WELL owners. A dial gauge that mounts inside your home that shows how many inches of water you have at all times. 100% guarantee. SALE. For more info.: Hellborn Innovations-2, 8036 Blinds Hollow Road, Sparta, IL 62286. Phone (618) 774-2500. Toll Free: (888) 333-7194.

LET THE GOVERNMENT PAY for your new or existing home. Over 100 different programs available. Free recorded message: (707) 448-3210. (8HX7).

TAYLOR SOFT SERVE MACHINES, single phase, double with twist, standby, guaranteed. Erio Sales, 2615 So. First, Springfield, IL 62704. (217) 522-3934.

CUSTOM SAWMILLING with Portable Woodmizer. Your place or mine. Call Jim Virkler, (815) 692-2890.

SHAWNEE NATIONAL FOREST in beautiful Southern Illinois. Properties for hunting, fishing, retirement. Call Ocie Paxton Realty at (618) 683-4203.

WANTED: ALL SPECIES standing timber; track of 20 acres or more. Clear-cutting if desired. Call Paul Jones, Ridgway, IL 62979. Phone (618) 272-3031.

SAVE YOUR LIFE! It's your body! Get inside story; amazing fantastic super wild food with no side effects. Guarantee. Free tape. Write: Independent Distributor-IL, P.O. Box 2633, Springfield, MO 65801. Toll free (888) 501-0133.

SEIZED CARS from \$175. Porsches, Cadillacs, Chevys, BMWs, Corvettes. Also Jeeps, 4WDs, your area. Toll free (800) 218-9000 Ext. A-14175 for current listings.

PLANNING A FLORIDA VACATION? Fish Haven Lodge on beautiful Lake Juliana is the place for you. Located in central Florida, only 30 min. from Disney World. Lakefront housekeeping cottages, adult mobile home park and large R.V. lots are available. Some of Florida's most reasonable rates. Write Fish Haven Lodge, Box 1, Fish Haven Road, Auburndale, FL 33823. Phone (941) 984-1183.

BECOME AN ORDAINED MINISTER by Correspondence Study. The harvest truly is great, Luke 10:2. Ministers for Christ, 3531 West Glendale Ave., Suite 211, Phoenix, AZ 85051. <http://www.ordination.org>.

LET THE GOVERNMENT FINANCE your new or existing small business. Grants/loans to \$80,000.00. Free recorded message: (707) 449-8600. (HX7).

PURPLE MARTIN BIRD HOUSE, 12 family unit, factory direct, \$59.95 retail, your price only \$29.95. Purple Martins eat 2,000 insects per day. Great gift! (800) 764-8688. Lifetime warranty.

Fiberglass corrugated, 26-inch wide. 8-10-12 foot long. 8 ft.-\$4. 12 ft.-\$6. Large supply, all colors. Dongola, IL (618) 827-4737.

AVON INCOME or discounts. Cosmetics, toys, collectibles, Barbies, much more! No door-to-door. Ind. Rep. Phone (800) 411-6323.

REGISTERED LLAMAS and MINIATURE DONKEYS. \$225 and up. 1987 GMC S16 Pickup, 4x4 with cap. Good condition - \$3,500. (618) 783-2169.

FREE CASH GRANTS! College, Scholarships. Business. Medical bills. Never Repay. Toll free (800) 218-9000, Ext. G-14175.

SUSPENDER WEARERS: Frustrated with suspenders that constantly slip off your pants? Our suspenders feature patented new clip. Lifetime "no-slip" guarantee. Brochure/order (800) 700-4515.

MCNESS PRODUCTS: Spices, seasonings, (famous) vanilla, extracts, soup, gravy bases, Krestol Salve, desert mixtures and home care products. Call (217) 854-8500.

MIDWEST BIRD and ANIMAL SWAP and sale: May 31 and June 28, at Monroe County Fairgrounds, Waterloo, IL (618) 939-6809.

SWENEY'S LLAMAS: Registered, breedings, exhibits, sales, fiber for spinning. FALL BABIES. Trained and ready to go. Farm visits welcome. Avon, IL (309) 465-3847.

\$55.00 FINDERS REWARD. Wanted: Meteorites, older jukeboxes, movie posters, Fender, Gibson, Martin, Gretch, National, Mosrite guitars, Harley, Indian motorcycles, etc. Call (314) 978-2788.

MINIATURE BALER: How to make. John Harp, RR 1, Easton, IL 62633.

IRRIGATION (217) 635-5713.

BLEACHER RECLINER™. Superior quality portable bleacher seat. (800) 621-2605 or www.swiftsite.com/brcorp

DISCOVER LLAMA MAGIC in Illinois with these beautiful, woolly creatures. For sale in a variety of colors and ages. (217) 868-5910.

LIP SMACKIN' GOOD! Five best, time-tested barbecue sauce recipes from GRILLMASTERS. Barbecue like the pros. Long SASE/\$3: Barbecue, P.O. Box 209, Elizabethtown, IL 62931-0209.

TRACTOR PARTS. New, used and rebuilt parts for Ford, Massey, Allis, International. Fast service, great prices. Tractor Barn, Brookline, MO. Call (800) 383-3678.

WATKINS PRODUCTS. ENHANCING LIVES since 1868. Rated among top 10 North American home-based businesses. Start under \$36. Free information, money-saving catalog. Successful independent representatives. (888) 556-7235.

TIRED of MOSQUITOES, GNATS? Invite the eradicator! Eats 10x more than Purple Martins. Complete housing instructions, information. Long SASE/\$2: NOBUGS, RR 2 Box 35, Elizabethtown, IL 62931-9160.

We buy and sell FRENCH, AMERICAN and JOHANN HAVILAND china, including the Blue Garland and Forever Spring patterns. (800) 952-7857. Fax (515) 285-0744.

FLOWER FAERIE FESTIVAL - June 6, 9 a.m. to 6 p.m. All day fun in the gardens. Magic, music, games and food. Pine Acres Trees and Herbs. Sidney, IL (217) 688-2207.

\$35,000 YEARLY INCOME! Homeworkers needed today! Assembly, clerical and mail processing jobs! For free information and job application, write: Charlin, Box 7158-P, Albuquerque, NM 87194.

Fishing and camping in remote quiet campground. 57 lakes and canals scattered across 183 acres of wooded property. FUN FOR a LIFETIME! (217) 784-8808.

WHITE HALL - 1 1/2 story home, many extras. Appraised for \$33,000. Selling for \$27,000! Call for details. (217) 374-2553.

SOAP - Handmade, herbal soaps are safe, gentle and fragrant. Send SASE for more information. Prairie Home Soap Co., RR2 Box 71, Moweaqua, IL 62550.

Steel Buildings



FACTORY DISCOUNTS UP TO
\$5,000.00 !!

- Ideal as a shop, garage & vehicle storage
- Protect your investments economically
- Up to 80' wide, unlimited lengths

CALL FOR SIZES

Limited time offer
1-800-581-5843



Classified Ad Order Form

Enclosed is \$_____ for the ad copy below to run _____ times starting with the _____ issue. Charges for each month's insertion, co-op members: \$8 for the first 20 words or less and 30 cents per additional word. Non-members: \$1.20 per word with a \$24 minimum for 20 words or less.

- All ads must be in one paragraph form. No centered copy. Maximum of four all-capital words per ad.
- **Check/cash/money order payable to Illinois Country Living and member's address label must accompany order.**
- Please type or print your ad neatly. You may use a

separate sheet if needed. Include your name, address and phone number. I am a member of _____ electric cooperative.

- The publisher reserves the right to reject any advertisement.

Mail to: Illinois Marketplace, Illinois Country Living
P.O. Box 3787 • Springfield, IL 62708

Deadline for August issue: June 15

The GOLF RETIREMENT FINDER will help you locate the perfect golf, tennis and fishing retirement communities in all sunshine states. (618) 995-9072.

Spend your weekends, day or holiday at CAVE IN ROCK, IL. No charge for children (14 years and under). The place where the movie, "How the West Was Won" was made. Also, one opening for November hunting season. Three openings for December hunting season. Call Ron (618) 289-3296 for information.

UNLIMITED TAX-FREE INCOME. Real opportunity. No scam, no hype. Simple, home-based. Guaranteed. Send LSASE: P.O. Box 200, Creal Springs, IL 62922.

Attention crafters and artists: Pine Acres Trees and Herbs FLOWER FAERIE FESTIVAL needs you! Sidney, IL. June 6. \$10 setup. (217) 688-2207.

CASH PAID FOR ANTIQUES, one piece or complete estates. (815) 473-4361.

WATKINS PRODUCTS SINCE 1868. Rated one of the top 10 home-based business - earn extra income! Free information packet. Rominger, RR 2 Box 135, Flora, IL 62839.

CARPET COMB removes up to 99 percent more soil and PET HAIR when used before vacuuming. Send \$19.95 to: W.T.I. Co., P.O. Box 452, Wadsworth, IL 60083.

AIR COMPRESSORS - Factory direct. Parts for all makes and models. Free Maintenance Schedule. (800) 735-3507.

20/20 WITHOUT GLASSES! Safe, rapid, nonsurgical, permanent restoration 6-8 weeks. Airline pilot developed. Doctor approved. Free information by mail: (800) 422-7320 Ext. 124, (406) 961-5570, FAX (406) 961-5577, <http://www.visionfreedom.com>. SATISFACTION GUARANTEED.

Are you feeling RUN DOWN and FATIGUED? The immune system is the key to better health. Strengthen that immune system and your body can fight off any attack. Announcing a breakthrough in natural healing, BETA 1, 3-D Glucan. Beta Glucan is safe, nontoxic, potent antioxidant and free radical scavenger, boosts the immune system, lowers blood sugar, reverses heart disease and decreases cholesterol and triglycerides. For more information call (888) 834-5788.

COLLOIDAL MINERALS - Quart \$9.95. Buy by the case - 40 percent discount. Case of 12 \$5.97 per quart. Call (800) 999-9345.

FREE BOLT BIN LABELS, save! Discounted hard bolt assortments, restocking grade 5/8, Baldwin farm fitters, lubrication equipment, shop items, hot water heating systems, personalized farm caps, shirts. Country Supply, 88S Jungle, Murphysboro, IL 62966.

TOP HOME-BASED BUSINESS! Low start-up, unlimited potential, free information. Watkins Independent Representative, P.O. Box 1, Wayne City, IL 62895. (618) 732-8233.

SAWMILL - Own your own money making Kasco mill for as little as \$4,320. The hub of our successful hardwood business for 14 years has been our Kasco mill. In stock, check it out today. Oak Leaf Wood 'N Supplies, 210 N. Main St., Moweaqua, IL 62550. "Illinois friendliest hardwood and craft supply source. Distributors of Kasco saw mills." Call mill (217) 768-4944 or store (217) 768-3202.

Wanted to buy: INDIAN ARTIFACTS of all kinds. One piece or entire collections. Call (309) 543-3847 evenings or leave message.

ATTENTION! ISN'T IT time you made some money? Herbal energizer! Super fat burner! Huge money-maker! FREE 3-day sample. Call (800) 836-3534.

CASH PAID for privately held real estate, mortgages, trust deeds. Purchases life insurance policies, lotteries, insurance settlements. SOMMERSET FUNDING! (800) 270-4469.

PASTRIES, PASTRIES, PASTRIES. The best pastry recipe around. Send \$2 to W.T.I., P.O. Box 452, Wadsworth, IL 60083.

NOW HIRING SALES MANAGERS - Business Entrepreneurs. Own your own franchise in the fastest growing MLM company. No monthly quota. Set your income. Opportunity of a lifetime with unequalled product in high demand. Call (800) 481-3181, then (618) 253-7790.

BUILDING MATERIAL OUTLET CENTER - 250# Shake Shingle - \$17/square; 3/4 OSB 4x8 \$10.99; 5/8 Pine Shop Siding \$15.99/sheet; other products available. 105 East Walnut, Murphysboro, IL (618) 684-2412. Ask for Charlie! MasterCard & VISA.

WALLPAPER - 300,000 rolls in stock. Save up to 70 percent off current book patterns. Call with books name and numbers. 1001 S. Court, Marion, IL. (618) 997-6090.

AKC ST. BERNARD PUPPIES. First shots, wormed. Both mother and father on premises. (618) 539-3139 evenings or weekends.

WHO DO YOU LOVE, your boss? Get rich slowly by helping others save money! Statewide expansion. Benefits. PT/FT positions. (800) 311-3481.

FOR SALE: USED SEMITRAILERS for storage, all sizes, swing and roll-up doors. \$1,400 and up. Also flatbeds available. I buy used trailers. Call John Kane at (708) 233-9880 day or (630) 595-4989 nights.

FEEL LIKE A "MILLION." Yes! Learn how to walk your way to easy, super fitness—and feel great! Get started right. Secrets revealed. \$12.95 - order now. C&A Enterprise, P.O. Box 762, Lawrenceville, IL 62439.

BUSY MOMS or DADS stay home. \$2,200 wk. Proven simple step by step system. Great support and training. Not MLM. 90 percent profit. Serious prospects, call (800) 995-0796, Ext. 8297.

Church Pew Padding

Add comfort and beauty to your church pews.
FREE info & fabric samples
Midwest Church Furnishings



Call 1-800-827-1482

TAN at HOME!

For as Low as **\$20 a Month**

BUY DIRECT & SAVE
HOME DELIVERY
Commercial Units Available



1-800-842-1324



HERITAGE BUILDING SYSTEMS

800-643-5555

BUILD IT YOURSELF AND SAVE

30 x 50 x 10	\$5,289
30 x 90 x 10	\$8,396
40 x 60 x 12	\$8,322
50 x 90 x 10	\$13,023
60 x 75 x 10	\$13,040
100 x 200 x 14-M1	\$50,082

Commercial steel buildings featuring easy bolt up assembly from America's largest distributor. We have over 10,000 standard sizes of shop, farm, industrial, commercial and mini-warehouse buildings. All are complete with engineer stamped permit drawings, 20 year roof and wall rust warranty. Call us today for a free information package and a quote on our top quality buildings or building component parts.

Mini Warehouse Sale
\$16,125
30' x 150' with 38 units complete with partitions
www.metabldg.com



Heartland

Capital Funding, Inc.

We purchase CRP and PFC government farm payments! Call 800-897-9825

CASH PAID!
Call for a Quote!

For Reliable Rural Buildings, Call

1-800-356-9682



Wick
Buildings®

Hawaii

FARM TOUR

THE BEST ESCORTED VACATION, YOU'LL EVER FIND.

15 DAYS
4 ISLANDS From **\$1814.**
ADD \$100 FROM EAST COAST

Departs every Tuesday, January 12 through January 26, 1999. Includes airfare, Hawaiian-owned hotels, transfers, baggage handling, Hawaiian escort flying with you from island to island, staying in OAHU, HAWAII (Kona & Hilo), MAUI and KAUAI. Sightseeing includes Honolulu City Tour with Pearl Harbor, Volcano National Park, Kona Coffee Plantation Tour, Parker Cattle Ranch Museum, Orchid Nursery, Macadamian Nut Factory Tour, Wailua Riverboat Cruise, Fern Grotto, Guava Plantation, plus more as listed in brochure.



Open 7 Days • Call for Free Brochure
Includes R/T Airfare • Groups Welcome
Price Based on Per Person Double Occupancy

1-800-888-8204

Our 31st Year • Over a million satisfied customers

MOBILE HOME ROOF PROBLEMS?

Our New Insulated Roof System For Mobile Homes Is The Permanent Solution.

LIFETIME WARRANTY

- * Eliminates Leaks
- * Eliminates Roof Noise
- * No More Roof Coating
- * Lowers Utility Bills
- * One Foot Overhang
- * Super Strong White Steel Roofing
- * 2" Thick Polystyrene Insulation



Call toll free for free information package and prices

SOUTHERN BUILDERS

1-800-633-8969



"Installing Mobile Home Roofovers Since 1983"

The Amazing Walk-Behind Brush Cutter!

NEW DR® FIELD and BRUSH MOWER

CLEAR & MAINTAINS meadows, pastures, woodlots, wooded and rough non-lawn areas with ease. CUTS tall grass, weeds, brambles, tough brush and even hardwood saplings up to 1" thick.

CHOPS/MULCHES most everything it cuts. Leaves NO TANGLE of brush to pick up like hand-held brushcutters and sicklebar mowers. Perfect for low-maintenance wildflower meadows, European-style woodlots, walking paths, or any area you only want to mow once a month or once a season!

- Up to 14 HP
- 4 Speeds
- Power Reverse



Mows up to 1 acre per hour!

Toll FREE (800) 641-0303

Pat. Pend.

Please mail this coupon TODAY for complete FREE DETAILS of the DR® FIELD and BRUSH MOWER including prices, specifications, and "Off-Season" Savings now in effect. There is no obligation.

Name _____

Address _____

City _____ State _____ ZIP _____

To: COUNTRY HOME PRODUCTS®, Dept. 3779F
Meigs Road, P.O. Box 25, Vergennes, VT 05491

BASIC
BRIDGES
\$225/UNIT
3 UNIT MIN.



BASIC
CROWNS
\$225

DENTURES • SAME DAY SERVICE
GENERAL DENTISTRY
FREE RV HOOKUPS
NOW 2 LOCATIONS TO SERVE YOU!

MID-AMERICA DENTAL CLINIC

J. Warren Hildreth Jr., D.D.S., P.C. of MO
558 E. Mt. Vernon Blvd. • Mt Vernon, MO • 65712
800-372-4554 • 417-466-4554

and

DENTAL CENTER/ Drs. Hildreth, Alvarez & Smith

Located at

MID-AMERICA DENTAL, HEARING & VISION CENTER

1050 W. Hayward Drive • Mt. Vernon, MO • 65712
800-354-1905 • 417-466-7197



5/31-6/7, International Carillon Festival, Rees Carillon, Springfield. In the only festival of its kind in the world, carilloneurs from many nations meet at Washington Park for a week of beautiful bell music. The Rees Carillon is one of the largest and finest of the world's carillons, featuring 66 bronze bells covering a range of 5.5 chromatic octaves. (217) 753-6219.

2-7/12, Quilt Show, DeWitt County Museum, Clinton. More than 50 quilts displayed in a 130-year-old Victorian Mansion. (217) 935-6066.

3, Marked for Life: My Travels on 66 in '53, Early American Museum, Mahomet. Terry Ryburn-Lamonte, director of Illinois State University's bureau of tourism and recreation research, recounts how a youthful excursion from Bloomington to California on Route 66 left her marked for life. (217) 586-2612.



6-7, New Salem Quilt Show, New Salem State Historic Site, Petersburg. Old and new quilts displayed on beds throughout the pioneer village once home to Abe Lincoln.

Other activities include demonstrations and quilt-block contest. (217) 632-4000.

5-7, StrawberryFest, Newton. Sample strawberry foods and homemade ice cream, arts and crafts, a double-nickel run, flea market, classic car show, photo contest, softball tournament, strawberry bake-off, livestock show, carnival games, pancake breakfast, music, games, contests, and entertainment. Sponsored by the Embarrass River Tourism Council. (618) 783-3399 or point your browser to www.psbnewton.com/ etc.

6, National Trails Day. A variety of activities are scheduled in several Illinois communities. For details of activities in your area, call (217) 789-4782.

6, River Ferry Boat Festival, Havana. Arts, crafts, antiques, city-wide garage sale, and ferry rides. (309) 543-3475.

6-7, Meredosia Riverfest, Meredosia. Historic to present-day river and related activities. Try your hand at making crow-foot hooks, cutting pearl button blanks, knitting fish nets and finding pearls in mussel shells. (217) 584-1536.

7, Fiberfest of Native American Weaving Traditions, Dickson Mounds Museum, Lewistown. A participatory outdoor event featuring the animals important to American Indian weavers — alpacas, llamas, sheep, and rabbits. Shearing, wool-carding, wool spinning, making and using natural dyes, finger and loom weaving, and making dream catchers. (309) 547-3721 or visit www.museum.state.il.us.

12, Dream Weavers, Dickson Mounds Museum, Lewistown. As they learn the weaving methods of American Indians through finger weaving and making dream catchers, children also will learn the Ojibwa legends of spider — the first weaver. (309) 547-3721 or visit www.museum.state.il.us.



12-14, Oldsmobile Balloon Classic Illinois, Vermilion County Airport, Danville. This is the largest hot-air balloon race (more than 100 balloons) in the state recognized nationally and internationally. (800) 383-4386.

Illinois Country Living publishes event listings as space allows, giving preference to events of regional or statewide interest. Event listings are provided by the event sponsors and the Illinois Bureau of Tourism. The magazine assumes no responsibility for the accuracy of information submitted for publication and advises calling ahead to confirm dates and times. To be considered for inclusion, send listings and photographs to Illinois Datebook, Illinois Country Living, PO Box 3787, Springfield, IL 62708-3787.



11-14, Superman Celebration, Metropolis. Opening ceremony balloon release, arts, crafts, Lois & Clark pool tournament, 3-on-3 basketball, bike trek and fun run/walk, super car show and cruise, talent show, entertainment, contest and carnival. (800) 949-5740.

12-14, Spirits Pow Wow, Oaks Campground near Geneseo. Inter-tribal gathering with dances, displays and games. (309) 944-3889 or (309) 658-2284.

13-14, Old Market Days/ Skills from the Hills, Galena. Living history example of turn-of-the century open-air market with farmer's hacks and stands offering produce, flowers, crafts, breads, and pastries sold by women in period costumes. Sponsored by the Jo Daviess County Association for Home and Community Education. (815) 858-3392.

13-14, Tour of Galena Homes, Galena. Tour the DeZoya House, built of two-foot thick native limestone in the 1830s by a steamboat captain and later owned by a soldier in Napoleon's Army. Two of the five homes featured have never been included on the annual tour, and three haven't been included in a decade. Sponsored by the Galena/Jo Daviess County Historical society. (800) 747-9377.

13-14, Living History Weekend, Fort Massac State Park, Metropolis. The Massiac Marines re-enact the 1750-1812 time period, demonstrating how people lived and coped with the hardships of early colonial life in a remote wilderness environment. (618) 524-9321.

18, Ways of Weaving, Dickson Mounds Museum, Lewistown. Introductory finger weaving traditions, including fiber and dye resources and weaving patterns. (309) 547-3721 or visit www.museum.state.il.us.

19-20, Grand Levee, Vandalia Statehouse, Vandalia. A period celebration with food, crafts and children's activities, candle-light tour of the Old Capitol Building. (618) 283-1161.

19-21, Illinois Special Olympics Summer Games, Illinois State University, Normal. Athletes from around the state compete in aquatics, golf, gymnastics, track and field and more. (309) 888-2551.

20-21, Gen. Grierson Days & Heritage Fair, Community Park, Jacksonville. A weekend honoring the Civil War general, featuring military re-enactment and social activities. (800) 593-5678.

20-21, Father's Day Bluegrass, Monticello Railway Museum, Monticello. Bluegrass jam and train rides. (800) 952-3396.

20-21, Garden Festival, David Davis Mansion, Bloomington. Gardening and cooking demonstrations and tours of the historic home of the Supreme Court justice. A gardener's market of live plants, dried flowers, and garden furnishings, too. Or take a self-guided tour through private gardens in the community. (309) 827-6026.

23-24, Mayfest, Mount Carroll. Music, arts and sports with continuous entertainment, food, quilt show, antiques and collectibles, 3-on-3 basketball, run/walk & bike

tour, and children's activities. (815) 244-4424 or (815) 244-2411.

25-28, Bloomington Gold Corvette Show, Bloomington. Corvette and car enthusiasts celebrate this show's return to Bloomington-Normal after a temporary shift to Springfield. (309) 829-3976.

28, Antique Auto Show, DeWitt County Museum, Clinton. Car show and tours of the museum. (217) 935-6066.

26-27, Western Days, Monticello. Enjoy stage coach and train rides, join in the golf ball race, or visit the Piatt County Museum, among other activities. (217) 762-7840.

27, Greenup Yard Sale & Craft Festival, Greenup. City-wide yard sales, craft and food booths, baseball card show. Sponsored by Cumberland Associates Senior Programs. Rain date, July 11. (217) 849-3065.

Ongoing:

6/8-8/8 – The Illinois Shakespeare Festival, the Midwest's leading outdoor homage to the bard, this year will present *The Falcon's Pitch*, a world-premier adaptation of Shakespeare's Henry VI Cycle, featuring actress Tandy Cronyn. The season also includes Shakespeare's comedies *Much Ado About Nothing*, and *Measure for Measure*. The festival also offers "family green" shows before every evening performance, during which patrons may enjoy a serenaded picnic dinner on the lawn of historic Ewing Manor plus mini-plays for kids and stage combat demonstrations. The festival features a museum dedicated to Shakespeare and his works, a gift shop and beautiful gardens to stroll on a lovely summer evening. Tickets and information are available by calling (309) 438-2535, or visit the festival's web site at www.orat.ilstu.edu/shakespeare.

FREE
with
purchase



Super Compact Canister

The 4-lb. dynamo you've seen on TV. The motor's so powerful it lifts a 16-lb. bowling ball! Hand-holdable and comfortable. Cleans under refrigerators... car seats... books... ceilings... even typewriter, computer and piano keys. With 8 accessories. Yours FREE when you purchase an ORECK XL upright. Offer limited, so act now.

Call toll-free 1-800-286-8900 Ext. 47010
Or Mail In This Coupon Today. No salesperson will visit.

- Yes, please call me to arrange a free 15-day home trial of the Oreck XL.
 Yes, I want to learn how I can get my home Oreck clean. Please send me a free information kit without cost or obligation. I understand I will receive absolutely free an ORECK Super Compact vacuum with the purchase of the ORECK XL vacuum cleaner.
 Also include details of ORECK's 12-month Payment Plan. No Interest or Finance Charge.

Mr. Mrs.
Name Ms. _____

Address _____

City _____ State _____ Zip _____

Telephone (_____) _____
area code 47010

Nothing gets by an
ORECK®

Oreck Direct, LLC, 100 Plantation Road, New Orleans, LA 70123

1990 ORECK HOLDINGS, LLC. All rights reserved. All trademarks are owned and used under the authorization of Oreck Holdings, LLC. A-2R

Sand, cat-hairs, dust and dust-mites... Nothing gets by the 8-lb. ORECK XL!

The favorite vacuum of thousands of hotels

and more than 1 million professional and private users. Now you can use this powerful vacuum to clean your home better than ever before.

Exclusive Filter System assures hypo-allergenic cleaning with Germastat®.

Ideal for those who suffer from dust-related or allergic discomforts. There's virtually no after dust. Its ingenious top-fill action carries the litter up through the handle and deposits it on the inside top of the bag. Yesterday's dirt can't seep out. And the metal tube top-fill performance works without hoses to crack, leak or break.

15-DAY
FREE
HOME
TRIAL

The lightest full-size vacuum available.

It weighs just 8 pounds. So stairs are a snap. It's super-powerful, with amazing cleaning power: the fast, double helical brushes revolve at an incredible 6,500 times a minute.

ORECK's Helping Hand® handle is orthopedically designed on the principles of ergonomics. To put it simply: no need to squeeze your hand or bend your wrist. A godsend for people with hand or wrist problems.

Exclusive New Microsweep® gets bare floors super clean, without any hoses, attachments or adjustments.

A full 10-year Guarantee against breakage or burnout of the housing PLUS a full 3-year Warranty on the Xtended Life, motor. We'll let you try the ORECK XL in your home for 15 days Free. If you don't love it, you don't keep it.



Amazing New Rose of Sharon BLOOMS IN 3 COLORS!



ONLY
\$5.99 ea.
Buy Two, get one
FREE!

3 Colors On One Shrub!

Here's a first: a bushy shrub with giant pink, white and blue flowers busily blooming for you all season long. No neighbor, friend or relative has this breathtaking tri-color combination of 4 inch blooms. It is available for the first time now through Michigan Bulb.

A Hardy Addition-

This unique three-in-one Rose of Sharon thrives in all areas of the country thanks to its Holy Land Heritage. With full sun and well-drained soil, it grows 10 to 12 feet tall, vibrantly coloring in any landscaping plan. Order yours today, while supplies last - just \$5.99 each. Or, **buy two and get one FREE!**

OUR LIFETIME GUARANTEE ▶ If you're not happy with any item you order from us, simply return it within 15 days for a full refund or replacement, your choice. Any items that fail to grow and flourish to your complete satisfaction will be replaced **FREE** for as long as you garden. **No time limit. No questions asked.**

MICHIGAN BULB COMPANY

1950 WALDORF NW • GRAND RAPIDS • MI 49550

F98 TP 3137 C 4

Please send my **ROSE OF SHARON** as indicated below for fall planting. My purchase is covered by your **LIFETIME GUARANTEE**.
No. 26765

1 for \$5.99*

Plus \$1.90 postage and handling.

2 for \$11.97*

Plus \$3.90 postage and handling.

PLUS 1 FREE!

**BUY TWO
GET ONE
FREE!**

MR. MRS.
MS MISS

Please Print

ADDRESS

CITY

STATE

ZIP

\$.

TOTAL AMOUNT

*MI res. add 6% sales tax.
*TN res add 8.25% sales tax.
*MO res add 4.225% sales tax.

Payment enclosed

Bill my credit card
(indicate card number and expiration date below)

VISA Mastercard

American Express Discover/NOVUS

Exp. Date

Exp. Date

Card No.

Card No.